

PROBILT SERIES

CUSTOMER PRODUCT MANUAL

ProBilt Series Adhesive Melters MODEL: PROBILT 8 & 15 w/ ACCUSCAN CONTROL SYSTEM

Thank you for purchasing another quality product manufactured by Universal Systems.

Please read this manual before unpacking and installing your new equipment. Safety and high quality are the design priorities for all Universal Systems products. Following the manual instructions will assure you a safe and reliable, long term performance of this product.

We strongly recommend that you keep this manual readily available for future reference.

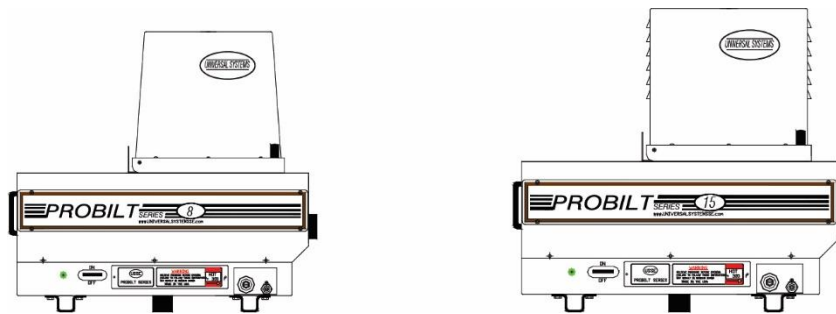

PROBILT SERIES

HOT MELT UNITS

UNIVERSAL SYSTEMS IS THE ONLY AUTHORIZED REPAIR CENTER FOR THE PROBILT SERIES HOT MELT UNITS AND THEIR COMPONENTS.

CONTACT THE UNIVERSAL SYSTEMS CUSTOMER SERVICE CENTER MONDAY THROUGH FRIDAY FROM 8:30AM TO 5:00PM E.S.T. FOR ADDITIONAL INFORMATION. **1-800-848-5018** Toll Free within U.S.A. or **+1-561-272-5442** for International Dialing.

PLEASE FILL IN THE INFORMATION BELOW UPON INSTALLATION FOR FUTURE REFERENCE.

TANK SERIAL NUMBER: _____ DATE RECEIVED: _____

TEMPERATURES

PRESSURES

TANK TEMPERATURE: _____ PUMP PRESSURE: _____

HOSE TEMPERATURE: _____

GUN TEMPERATURE: _____ GUN PRESSURE: _____

Universal Systems SE Inc.

1085 15th Avenue, Bldg E

Delray Beach, FL 33444

www.USSEFL.com

Phone: 561-272-5442

Fax: 561-431-2877

TECH@USSEFL.com

SALES@USSEFL.com

TABLE OF CONTENTS

	<u>PAGE</u>
SECTION 1 – SAFETY PRECAUTIONS	
• INTRODUCTION	1
• SAFETY SYMBOLS	1
• INSTALLATION SAFE GUARDS	1
• OPERATING SAFE GUARDS	2
• SERVICE SAFE GUARDS	2
• SAFE GUARDS WHEN USING HOT MELT ADHESIVES	3
SECTION 2 – FEATURE OVERVIEWS	
• INTRODUCTION	4
• STANDARD FEATURES	4
• OPERATIONAL FEATURES	5
• SPECIFICATIONS	5
• CONTROL SYSTEM	6
• STARTUP MODE	6
• SCAN MODE	6
• STANDBY MODE	7
• FAULT ALARM	7
• EXTERNAL FAULT ALARM	7
• PARENT MACHINE INTERLOCK	7
SECTION 3 – TANK AND COMPONENT ELECTRICAL DATA	
• INTRODUCTION	8
• SYSTEM AND COMPONENT ELECTRICAL DATA	8
SECTION 4 – INSTALLATION PROCEDURES	
• INTRODUCTION	9
• UNPACKING	9
• INSTALLATION	9
• EXTERNAL FAULT ALARM (EFA)	11
• CONNECTING THE EFA	12
• PARENT MACHINE INTERLOCK (PMI)	12
• CONNECTING THE PMI	12
SECTION 5 – SYSTEM PROGRAMMING PROCEDURES	
• INTRODUCTION	13
• SYSTEM CONTROLS	13
• KEY FUNCTIONS	13
• PROGRAMMING SYSTEM SETTINGS	14
SECTION 6 – OPERATING PROCEDURES	
• SAFETY	15
• START-UP PREPARATION	15
• STANDBY MODE	16
SECTION 7 – MAINTENANCE GUIDELINES	
• INTRODUCTION	17
• PREVENTATIVE MAINTENANCE	17
• FILTER CHANGE	17
• SYSTEM CLEANING	18

SECTION 8 - TROUBLESHOOTING

• INTRODUCTION	19
• SERVICE	19
• OVERVIEW OF LED INDICATORS	19
• PISTON PUMP TROUBLESHOOTING	21
• TANK HEATER TROUBLESHOOTING	22
• HOSE TROUBLESHOOTING	22
• GUN TROUBLESHOOTING	23
• CIRCUIT BREAKER TROUBLESHOOTING	23
• HOT MELT ADHESIVE TROUBLESHOOTING	24

SECTION 9 - PARTS AND COMPONENTS REPLACEMENT

• INTRODUCTION	27
• SERVICE	27
• PUMP ASSEMBLY REPLACEMENT	27
• PUMP SHIFTER REPLACEMENT	28
• FILTER ASSEMBLY REPLACEMENT	29
• CONTROL PANEL ASSEMBLY REPLACEMENT	29
• TANK TRIAC REPLACEMENT	30
• CIRCUIT BREAKER REPLACEMENT	30
• TANK THERMOSTAT AND RTD REPLACEMENT	31

SECTION 10 - FIGURE DRAWINGS

• INTRODUCTION	32
• FIGURE 1A	33
• FIGURE 1B	34
• FIGURE 2	35
• FIGURE 3	36
• FIGURE 4	37
• FIGURE 5A	38
• FIGURE 5B	39
• FIGURE 6	40
• FIGURE 7	41
• FIGURE 8	42
• FIGURE 9	43
• FIGURE 10	44
• FIGURE 11	45
• FIGURE 12	46
• FIGURE 13	47
• FIGURE 14	48
• FIGURE 15	49
• FIGURE 16	50
• FIGURE 17	51

SECTION 1 – SAFETY PRECAUTIONS

INTRODUCTION

In order to ensure that the PROBILT SERIES hot melt unit is installed and operated in the safest manner possible, the subsequent safety procedures should be followed at all times. Failure to follow these procedures may result in serious injury to personnel as well as damage to property and equipment.





The following material covers symbols posted on the PROBILT SERIES hot melt unit, installation safety, operation safety, and safety when using hot melt adhesives.

SAFETY SYMBOLS

Safety symbols and information are posted at various points on the PROBILT SERIES hot melt unit.

OPERATORS OF THE EQUIPMENT SHOULD BECOME FAMILIAR WITH WHERE THESE SAFETY SYMBOLS ARE LOCATED AND WHEN THEY APPLY DURING OPERATION.

Shown below are the three warning symbols you will find on the PROBILT SERIES hot melt unit and what they represent.

ELECTRICAL GROUND	HIGH VOLTAGE	HOT SURFACE	UNDER PRESSURE
			

INSTALLATION SAFE GUARDS

PNEUMATIC

- In the air supply line to the filter regulator, a manual three-way lockout valve should be installed. This will enable air pressure to be relieved and the pneumatic system locked out before undertaking any service or repairs.

SEE "FIGURE 12" FOR IDENTIFICATION OF YOUR PUMP SHIFTER

ELECTRIC

- In order to prevent power surges and a possible fire, fuses of the correct voltage and current ratings must be used at all times.
- Always provide a disconnect switch with lockout capability between the equipment and the source of power to your machine.
- It is necessary that the power supply wire meets the power and temperature requirements for the machine. Proper insulation and wire gauge are required.
- All components, even those that are insulated, have the ability to send off an electric shock when not grounded properly. You must provide an electrical ground connection to an unfailing earth ground in order to prevent this from occurring.

OPERATING SAFE GUARDS

THE PROBILT SERIES HOT MELT UNIT SHOULD NEVER BE OPERATED IF THE FOLLOWING CONDITIONS EXIST:

- Safety guards, panels, and covers have not been secured in their proper location.
- Hoses have been enclosed in materials that interfere with heat dissipation, including insulation, tight metal covers, or electrical conduit.
- Temperatures are colder than 20° F or hotter than 120° F.
- Explosive and/or volatile materials and gasses are present.
- Handgun triggers (if used) are left unlocked while the gun is unattended.
- Hoses have been left on cold surfaces, such as floors or supports. This may create a problem in the flow of the adhesive being used and will lead to problems within the system.
- Hoses have been unshielded from wind or drafts while being used outdoors or in drafty areas. Air movement will cause rapid heat dissipation across the guns and lead to operational problems with the guns.
- Pressure is higher than the maximum rated operating pressure of the components in the system.

PLEASE NOTE:

- Equipment covers, panels, doors, or hose connectors cannot be used to either lift or move an applicator. Only use the metal base when attempting to do so.
- Hoses cannot be installed at a bend radius of less than 6 inches. All hoses are to be routed in a manner to prevent all damage such as kinking or abrasion.
- Guns are never to be pointed toward yourself or anyone in the general vicinity of the unit.

SERVICE SAFE GUARDS

IF A PROBLEM OCCURS WITH THE PROBILT SERIES HOT MELT UNIT, IMMEDIATELY CONTACT UNIVERSAL SYSTEMS BEFORE TRYING TO SERVICE THE UNIT YOURSELF.

- Universal Systems trained personnel are readily available to help you if you are having a problem with your hot melt unit.
- **Only qualified personnel should attempt to service the PROBILT SERIES hot melt unit.** Even qualified personnel must consult with a Universal Systems technician before attempting service.



1. There are dangerous voltage points throughout the system.

IN ORDER TO PREVENT ELECTRICAL SHOCK NEVER TOUCH EXPOSED COMPONENTS AND/OR CONNECTIONS WHEN POWER IS ON.

2. Prior to replacing electrical components or removing panels, make sure you have disconnected, locked out, and tagged external electrical power.
3. Make sure work areas and exposed terminals are covered with rubber sheeting so contact is avoided while the power is **ON**.
4. You must stand on a rubber mat when servicing the unit.
5. **NEVER** work on the PROBILT SERIES hot melt unit when/where standing water is present.
6. Atmospheres with high humidity should be avoided when servicing the PROBILT SERIES hot melt unit.



7. In order to prevent personal injury due to hot adhesives, hot gun surfaces, and hot applicator parts, make sure proper safety equipment is worn at all times. This includes safety glasses, protective gloves, and long sleeved protective clothing.



8. System hydraulic pressure should be relieved before any hydraulic connection or fitting is opened. This will prevent serious injury from molten adhesives that are under pressure.

SAFE GUARDS WHEN USING HOT MELT ADHESIVES

- **NEVER** attempt to remove molten material that has come into contact with the skin.
- Immerse the affected area immediately in cold, clean water. Keep affected area in the water until the molten material has cooled.
- **NEVER** attempt to remove the cooled material from the skin.
- Using a clean and wet compress, cover the affected area.
- **OBTAIN MEDICAL ATTENTION IMMEDIATELY**

SECTION 2 – FEATURE OVERVIEWS

INTRODUCTION

The PROBILT SERIES hot melt unit is the most economical, simple to operate and virtually maintenance free glue unit ever developed. State of the art engineering of long lasting components ensures extended service life, less downtime and greater consumer flexibility that is sure to outlast and out perform similar competing products in the industry.

The PROBILT SERIES hot melt unit has an operating range of 100°F - 425°F, making it ideal for use with today's low temperature adhesives. Designed to handle low, medium or high volume adhesive consumption, this unit is engineered for low to medium speed case sealing, medium to high speed carton sealing and a wide variety of similar applications.

Once again, Universal Systems continues to meet the demands of today's advancing technology in the hot melt industry with simplicity, reliability and unequalled product durability.

STANDARD FEATURES

Listed below are some of the standard features you will find on the PROBILT SERIES hot melt unit:

- User-friendly design for easy installation, simplistic operation, and minimal maintenance.
- Patent pending, simple to operate, AccuScan™ Control System with solid state keypad temperature controls for melt tank, hoses and guns.
- “One touch” setback key for standby mode.
- Precise RTD temperature control with self diagnostic digital temperature readings within +/- 1°F.
- Under temperature and over temperature protection on all zones with a visual and audible fault alarm.
- Automatic scanning of all enabled zones.
- Parent machine interfacing.
- External fault alarm interfacing.
- The removal of four button head screws allows total access to all electrical components for ease of maintenance and service.
- Sequential heating (tank and hoses heat prior to guns for increased life of components).
- All electrical components are installed with “quick” disconnects for a fast plug and run installation.
- High flex, automatic heated hoses are stocked in lengths of 2, 4, 6, 8, 10, 12, 14, 16, 18, 20, 24, 30, 32 and 36 feet. Custom hose lengths are available upon request.

SEE “PARTS CATALOG” FOR HOSE INFORMATION OR CONTACT OUR CUSTOMER SERVICE DEPARTMENT

- Various types and styles of extrusion guns can be used with the PROBILT SERIES hot melt unit.

SEE “PARTS CATALOG” FOR GUN INFORMATION OR CONTACT OUR CUSTOMER SERVICE DEPARTMENT

- Cast in tank heater with a 10-year warranty for long lasting, trouble free heating.
- Stainless steel and high strength aluminum construction allows easy cleaning and unequalled durability.

OPERATIONAL FEATURES

- Front mounted, easy access on/off circuit breaker.
- Standard Teflon® coated tank to reduce build up of charred glue.
- Tank screen and front mounted manifold filter for removal of contaminants and easy cleaning.
- Front mounted drain valve for convenient draining of tank for maintenance or service.
- 14:1 ratio balanced piston pump with a long life, reverse without stalling shifter for a “no pressure drop” operation.
- Self-sealing, full opening lids allow for easy loading of adhesive and tank cleaning.

SPECIFICATIONS

ALL SPECIFICATIONS OF THE PROBILT SERIES HOT MELT UNIT ARE SUBJECT TO CHANGE DUE TO INDUSTRY DEVELOPMENTS OR ENHANCEMENTS TO THE UNIT ITSELF.

PROBILT SERIES 8	PROBILT SERIES 15	
<ul style="list-style-type: none"> • 8 lb tank capacity. • 13 lbs/hr system melt rate. • 75lbs/hr @ 3200 centipoise pump rate. • 850 - 31,000 centipoise viscosity range. • On board microprocessor. • 4 digit LCD temperature and system status display. • Green, amber and red LED status indicators. • On board fuse circuit protection. • ±1° F temperature control stability. • 100° F - 425° F operating temperature range. • 32° F - 120F° ambient temperature range. • Minimum of 1 – maximum of 4 hose operation. • 200VAC - 230VAC, 50/60Hz, single or three phase electrical requirement. 	<ul style="list-style-type: none"> • 15 lb tank capacity. • 20 lbs/hr system melt rate. • 75lbs/hr @ 3200 centipoise pump rate. • 850 - 31,000 centipoise viscosity range. • On board microprocessor. • 4 digit LCD temperature and system status display. • Green, amber and red LED status indicators. • On board fuse circuit protection. • ±1° F temperature control stability. • 100° F - 425° F operating temperature range. • 32° F - 120F° ambient temperature range. • Minimum of 1 – maximum of 4 hose operation. • 200VAC - 230VAC, 50/60Hz, single or three phase electrical requirement. 	

<ul style="list-style-type: none"> • 5500 Watts @ 230VAC maximum system wattage. • System capacity (total wattage of melt tank, hoses and guns) is not to exceed 5500 Watts @ 230VAC. <p>SEE "SECTION 3" FOR TANK AND COMPONENT ELECTRICAL DATA</p> <ul style="list-style-type: none"> • 20psi - 60psi recommended pump operating air pressure. • 1500psi maximum working hydraulic pressure @ 125psi. • SEE "FIGURE 1A" FOR DIMENSIONS OF THE HOT MELT UNIT • System weight is approximately 59 lbs (empty). 	<ul style="list-style-type: none"> • 5500 Watts @ 230VAC maximum system wattage. • System capacity (total wattage of melt tank, hoses and guns) is not to exceed 5500 Watts @ 230VAC. <p>SEE "SECTION 3" TANK AND COMPONENT ELECTRICAL DATA</p> <ul style="list-style-type: none"> • 20psi - 60psi recommended pump operating air pressure. • 1500psi maximum working hydraulic pressure @ 125psi. • SEE "FIGURE 1B" FOR DIMENSIONS OF THE HOT MELT UNIT • System weight is approximately 69 lbs (empty). 	
---	---	--

CONTROL SYSTEM

The AccuScan™ Control System is the simple to operate command center of the PROBILT SERIES hot melt unit. The easy to program AccuSet Controller allows the operator to individually regulate the temperature of each zone and monitor the system status through the 4 digit display and LED indicator lamps. The AccuSet Controller is designed to retain all program settings either when the unit is turned off or if a power failure or brown out should occur.

All zones have a green LED status indicator mounted on the control panel. In addition, there is a green "HEAT ON/ZONE STATUS" LED, which indicates the heat status of a zone; a red "ALARM" LED, which along with an audible alarm, will glow and indicate through the digital display a fault condition; and an amber "SETBACK" LED which glows to indicate when the systems is in standby mode.

SEE "FIGURE 3" FOR DETAILS OF THE LED INDICATORS

STARTUP MODE

The AccuScan™ Control System is programmed for a sequential startup when the operator turns the system on. The melt tank and hoses begin to heat first. Once the temperatures of the tank and hoses are all within 35°F of their setpoint temperatures, the guns will begin to heat.

When the melt tank, hoses, and guns are within 5°F of setpoint temperature, the green "HEAT ON/ZONE STATUS" LED will begin to flash when a zone that is at setpoint temperature is displayed, either manually or by AccuScan™.

WHEN THE PROBILT SERIES HOT MELT UNIT IS IN STARTUP MODE, THE PUMP IS DISABLED UNTIL THE MELT TANK TEMPERATURE IS WITHIN 35 °F OF SETPOINT TEMPERATURE.

SCAN MODE

When the system is operating, the actual temperature of each zone is displayed in sequence when the AccuScan™ is enabled.

ANY ZONES THAT ARE "OFF" WILL NOT BE SCANNED.

As a zone is scanned, the green zone LED will glow, the display will indicate actual temperature, and the “HEAT ON/ZONE STATUS” LED will either be flashing, which indicates zone has reached setpoint temperature (within 5°F) or glowing solid which indicates zone is still heating. If “HEAT ON/ZONE STATUS” LED is off, the zone being scanned is slightly above setpoint temperature (approximately 2°F). This is a normal condition. It will begin to flash once the zone drops back to setpoint temperature. A zone is not calling for heat if the “HEAT ON/ZONE STATUS” LED is off.

WHEN ACCUSCAN™ IS DISABLED, ONLY THE TEMPERATURE FOR THE SELECTED ZONE IS DISPLAYED.

STANDBY MODE

When the “SETBACK” feature is enabled, the amber LED will begin to glow, and the control system reduces the temperature of all enabled zones to 165°F. This feature allows for the operator to keep the adhesive warm while normal operation is interrupted, thus reducing char formation and conserving energy.

FAULT ALARM

When a fault conditions occurs, the red “ALARM” LED will begin to glow and an internal alarm will sound. In addition the External Fault Alarm (EFA) will signal any connected external visual or audible alarm.

The 4 digit display will indicate “ rtdH ” or “ HtrL ” and the scan mode will be disabled. The controller will identify the zone with the fault condition by remaining on that zone. All other zones will remain functioning.

SEE “SECTION 8” FOR DETAILS OF FAULT INDICATORS

In addition, should the tank zone exceed 450°F, the entire system will shut down. If this condition should occur, the operator will not be able to reset the unit circuit breaker until the tank temperature drops below 450°F.

SEE “SECTION 8” FOR DETAILS OF CIRCUIT BREAKER OPERATION

EXTERNAL FAULT ALARM

External fault alarm is a feature that is standard on all PROBILT SERIES hot melt units. When a fault condition occurs it energizes a normally open dry contact which may be used to signal an external visual or audible alarm.

PARENT MACHINE INTERLOCK

Parent machine interlock is a feature that is standard on all PROBILT SERIES hot melt units. Its function is to prevent the parent machine from operating before the hot melt system is ready. When all enabled zones are within 12°F of setpoint temperature, it energizes a normally open dry contact which may be used to signal the parent machine.

SECTION 3 – TANK AND COMPONENT ELECTRICAL DATA

INTRODUCTION

The following information will enable qualified personnel to determine the electrical requirements necessary to power their specific system.

SYSTEM AND COMPONENT ELECTRICAL DATA

PART NUMBER	ITEM DESCRIPTION	VOLTAGE	WATTAGE
D100-944 D100-744	8 LB. CAST IN TANK HEATER 15 LB. CAST IN TANK HEATER	200 - 230 200 - 230	1250 1750
4102 4104 4106 4108 4110 4112 4114 4116 4118 4120 4124 4130 4132 4136	2FT. HIGH FLEX HEATED HOSE 4FT. HIGH FLEX HEATED HOSE 6FT. HIGH FLEX HEATED HOSE 8FT. HIGH FLEX HEATED HOSE 10FT. HIGH FLEX HEATED HOSE 12FT. HIGH FLEX HEATED HOSE 14FT. HIGH FLEX HEATED HOSE 16FT. HIGH FLEX HEATED HOSE 18FT. HIGH FLEX HEATED HOSE 20FT. HIGH FLEX HEATED HOSE 24FT. HIGH FLEX HEATED HOSE 30FT. HIGH FLEX HEATED HOSE 32FT. HIGH FLEX HEATED HOSE 36FT. HIGH FLEX HEATED HOSE	200 - 230 200 - 230 200 - 230 200 - 230 200 - 230 200 - 230 200 - 230 200 - 230 200 - 230 200 - 230 200 - 230 200 - 230 200 - 230 200 - 230	50 120 180 240 300 360 420 480 540 600 720 900 960 1080
4602 4604 4606 4608 4610 4612 4614 4616 4618 4620 4624 4630 4632 4636	2FT. STANDARD FLEX HEATED HOSE 4FT. STANDARD FLEX HEATED HOSE 6FT. STANDARD FLEX HEATED HOSE 8FT. STANDARD FLEX HEATED HOSE 10FT. STANDARD FLEX HEATED HOSE 12FT. STANDARD FLEX HEATED HOSE 14FT. STANDARD FLEX HEATED HOSE 16FT. STANDARD FLEX HEATED HOSE 18FT. STANDARD FLEX HEATED HOSE 20FT. STANDARD FLEX HEATED HOSE 24FT. STANDARD FLEX HEATED HOSE 30FT. STANDARD FLEX HEATED HOSE 32FT. STANDARD FLEX HEATED HOSE 36FT. STANDARD FLEX HEATED HOSE	200 - 230 200 - 230 200 - 230 200 - 230 200 - 230 200 - 230 200 - 230 200 - 230 200 - 230 200 - 230 200 - 230 200 - 230 200 - 230 200 - 230	50 120 180 240 300 360 420 480 540 600 720 900 960 1080
39101 39107 39110 39201 39241 39301 39401 39441 3281 3471	1 MODULE GUN 1 MODULE GUN 1 MODULE WASHDOWN GUN 2 MODULE GUN, 2.31 CENTERS 2 MODULE GUN, .88 CENTERS 3 MODULE GUN, .88 CENTERS 4 MODULE GUN, .88-1.5-.88 CENTERS 4 MODULE GUN, .88 CENTERS 2 MODULE GUN, LOW PROFILE 4 MODULE GUN, LOW PROFILE	200 - 230 200 - 230 200 - 230 200 - 230 200 - 230 200 - 230 200 - 230 200 - 230 200 - 230 200 - 230	150 150 150 210 200 250 300 300 200 310

LISTED ABOVE ARE THE MOST POPULAR HOSES AND GUNS MANUFACTURED BY UNIVERSAL SYSTEMS A WIDE VARIETY OF HOSES AND GUNS ARE AVAILABLE.

SEE "PARTS CATALOG" FOR AVAILABLE HOSES AND GUNS OR CONTACT OUR CUSTOMER SERVICE DEPARTMENT

SECTION 4 – INSTALLATION PROCEDURES

INTRODUCTION

This section of the manual contains important information for installing the PROBILT SERIES hot melt unit.

SEE "SECTION 1" FOR SAFETY PROCEDURES PRIOR TO INSTALLING THE UNIT

UNPACKING

The PROBILT SERIES hot melt unit is delivered to the customer already assembled. Care should be taken while removing the packaging material and the unit from the box in order not to cause personal injury or damage to the unit itself.

NEVER LIFT THE UNIT BY THE HOSE CONNECTORS, CONTROL PANEL HANDLES, OR ANY STAINLESS STEEL PANEL ON THE UNIT. LIFT THE PROBILT SERIES HOT MELT UNIT BY THE BASE ONLY.

INSTALLATION

REQUIREMENTS

- The PROBILT SERIES hot melt unit should be placed in an area where the end panels and pump cover can be easily removed and operator accessible.
- At all times make sure that the unit is protected from extreme vibration and areas where there is a large amount of dust.
- The PROBILT SERIES hot melt unit should overhang the support platform by approximately 2 inches in order that a container may be placed beneath the drain valve for service.
- Do not place the unit in places where the temperature is below 32° F or above 120° F.



- The PROBILT SERIES hot melt unit is not designed for water washdown. If this occurs, water may enter the unit and cause serious damage and/or electrical shock.

NEVER SPRAY WATER ON OR NEAR THE PROBILT SERIES HOT MELT UNIT.

UNIT INSTALLATION

- The PROBILT SERIES hot melt unit should be mounted securely in its location, always making sure clearances for the controls, panels, and connections are met.

SEE "FIGURE 1A, 1B & 1C" FOR DIMENSIONS OF THE PROBILT SERIES HOT MELT UNIT

- Provided on the base of the unit are two mounting rails with four mounting bolt holes. 5/16 Inch bolts must be used in order to gain the sturdiest mount possible.

- Make sure that the hoses are routed from the guns to the unit and do not allow them to be installed with a bend radius of less than 6 inches.
- Using the fittings provided with the PROBILT SERIES hot melt unit, tightly connect the first hose to the port beneath the electrical hose connection marked 1. If more than one hose is in use, install the additional hoses in number order, as labeled on the electrical hose connections above the ports.
- Air pressure should be set at zero to the pump during installation.
- Connect an air supply with a minimum of 80psi to the air filter regulator (PART# 5307) included with the unit. The air filter regulator has ¼ inch NPT threads (make sure that a Teflon® paste is used on these threads).

SEE "FIGURE 12" FOR IDENTIFICATION OF YOUR PUMP SHIFTER

- Hoses are electrically connected to the unit by inserting the hose plugs into the electrical hose connections.

ELECTRICAL INSTALLATION

The PROBILT SERIES hot melt comes wired from the factory to accept 200 - 230 VAC three-phase services. Applicators can be modified by adding a single internal jumper provided with the unit that is capable of accepting single-phase service.



MAKE SURE EXTERNAL POWER IS DISCONNECTED BEFORE ANY ELECTRICAL ENCLOSURE IS OPENED.

Even if the circuit breaker on the front of the PROBILT SERIES hot melt unit is turned off, the input terminal board and the input terminals on the main circuit breaker will still be electrically charged if the unit is not disconnected from its outside power source.



NEVER TOUCH THE BLACK HEAT SINKS THAT EXTEND FROM THE CIRCUIT BOARD WHEN POWER IS GIVEN TO THE UNIT.

The black heat sinks are electrically charged and will give off an electric shock if touched when power is being given to the unit.



NEVER CONNECT THREE PHASE POWER TO A UNIT CONFIGURED FOR SINGLE PHASE.

CONNECTING POWER

1. All input electrical power should be disconnected and locked out.
2. Remove the electrical access panel on the back of the cabinet by unscrewing the four button head screws that hold it in place.

A WIRING DIAGRAM FOR BOTH SINGLE AND THREE PHASE HOOK UP WILL BE LOCATED ON THE REVERSE SIDE OF THE PANEL..

3. Remove the control panel on the left side of the cabinet by unscrewing the four button head screws. Then, grasp the two control panel handles, tilt the panel forward, and then pull up and out. This will allow full access to the terminal block mounted in front of the access panel.

SEE "FIGURE 6A, 6B & 6C" FOR REMOVAL OF THE CONTROL PANEL

4. The input power line may be routed through either conduit openings located in the lower left side of the unit base.

SEE "FIGURE 5A, 5B & 5C" FOR CONDUIT OPENINGS

5. Connect three phase or single phase service to the terminal block connections as follows

SEE "FIGURE 5A, 5B & 5C" FOR TERMINAL BLOCK CONNECTIONS

200-230 VAC Three Phase

L1 - Power Lead

L2 - Power Lead

L3 - Power Lead



- Ground Wire

200-230 VAC Single Phase

L1 - Power Lead

L2 - Power Lead

L3 - Do Not Use



- Ground Wire

Install the jumper between the two terminals labeled 1ØJ on the circuit board green power terminal plug labeled J7.

SEE "FIGURE 8" FOR J7 CONNECTOR

6. Replace the control panel and secure with the four button head screws.
7. Replace the electrical access panel and secure with the four button head screws.

EXTERNAL FAULT ALARM (EFA)

The External Fault Alarm provides a set of dry contacts that may be used to signal an external visual or audible alarm.

SEE "FIGURE 5A, 5B & 5C" FOR PMI CONNECTION

CONNECTING THE EFA

1. All input to electrical power should be disconnected and locked out.
2. Remove the system control panel on the left side of the cabinet by removing the four button head screws.

SEE "FIGURE 6A, 6B & 6C" FOR REMOVAL OF THE CONTROL PANEL

3. Locate the two part terminal block marked ALARM and carefully remove the plug.
4. Route the leads for the EFA through the unused electrical knock located in the base of the unit.
5. Connect the leads to the plug. Either lead may go to either screw, as the contact is not polarity sensitive.
6. Re-connect the plug to the board receptacle.
7. Replace the system control panel and secure with the four button head screws.

PARENT MACHINE INTERLOCK (PMI)

The AccuScan™ Control System provides a set of dry contacts that may be used to signal the parent machine when the hot melt system is ready to run.

SEE "FIGURE 5A, 5B & 5C" FOR PMI CONNECTION

CONNECTING THE PMI

8. All input to electrical power should be disconnected and locked out.
9. Remove the system control panel on the left side of the cabinet by removing the four button head screws.

SEE "FIGURE 6A, 6B & 6C" FOR REMOVAL OF THE CONTROL PANEL

10. Locate the two part terminal block marked PMI and carefully remove the plug.
11. Route the leads for the PMI through the unused electrical knock located in the base of the unit.
12. Connect the leads to the plug. Either lead may go to either screw, as the contact is not polarity sensitive.
13. Re-connect the plug to the board receptacle.
14. Replace the system control panel and secure with the four button head screws.

SECTION 5 – SYSTEM PROGRAMMING PROCEDURES

INTRODUCTION

The PROBILT SERIES hot melt unit is shipped after thorough testing of all zones (tank, hose and gun). Once testing is complete, all zones are turned **OFF** with exception to the tank, which is set at 235°F.

The following information will show you how to custom program the AccuScan™ Control System to your specific operation once the unit has been received. Before you begin programming, you may find it helpful to read the control system information, which describes the system functions.

SEE "SECTION 2" FOR CONTROL SYSTEM FEATURES & INFORMATION

SYSTEM CONTROLS

The five system control keys of the AccuSet Controller allow the operator to control all of the system operations. By using the keys, you can:

- Turn a zone **ON** or **OFF**.
- Increase or decrease zone temperatures.
- Monitor the status of a particular zone.
- Automatically scan each zone to check the system status (referred to as AccuScan™ throughout this manual).
- Enable the entire system into setback temperature for stand by mode.

KEY FUNCTIONS

ZONE KEY

- Press to select a desired zone for programming or status display.

UP ARROW KEY (RED)

- Press to enable a zone.
- Increase a zone setpoint temperature.

DOWN ARROW KEY (BLUE)

- Press to disable a zone.
- Decrease a zone setpoint temperature.

SET KEY

- Press to view any setpoint temperature at any time.

SETBACK KEY

- Press to enable entire system into standby mode (165°F).
- Press again to disable standby mode.

PROGRAMMING SYSTEM SETTINGS

The following procedures are for programming the AccuSet Controller for standard operation.

STARTUP

Turn the power **ON** to the unit by flipping the circuit breaker, located on the lower front left panel, to the up position. Make sure the green power light is glowing. Two beeps will sound from the control system indicating it is energized.

The tank will begin heating to the preset factory temperature of 235°F. All hose and gun zones are **OFF**.

SEE BELOW FOR TANK TEMPERATURE PROGRAMMING AND TO ENABLE YOUR HOSE AND GUN ZONES

TEMPERATURE PROGRAMMING

1. Press the ZONE key to select the desired zone to be displayed. The corresponding zone LED will glow solid green.
2. Press the SET key to view the setpoint temperature.
3. Press and hold the SET key and then use either the UP ARROW key (red) to increase the zone setpoint temperature or the DOWN ARROW key (blue) to decrease the setpoint temperature.

TO TURN A ZONE OFF, PROGRAM THE SETPOINT TEMPERATURE TO LESS THAN 100 °F. THE DISPLAY WILL READ "OFF".

ACCUSCAN™ MODE

1. Press the UP ARROW (red) and the DOWN ARROW (blue) keys together to enable the AccuScan™ mode.
2. Press the ZONE key to disable the AccuScan™ mode.

STANDBY MODE

1. Press the SETBACK key to enable the system into standby mode. The amber LED will begin to glow and all zones will hold a setpoint temperature of 165°F.
2. Pressing the SETBACK key again will disable the standby mode and all zones will heat to their preselected setpoint temperatures.

CHANGING TEMPERATURE DISPLAY FROM FAHRENHEIT TO CELSIUS

1. Press and hold the DOWN key and the ZONE key at the same time for 3 seconds to toggle from Fahrenheit to Celsius.
2. Repeat step 1 to change back to Fahrenheit.



SECTION 6 – OPERATING PROCEDURES

SAFETY

ALWAYS MAKE SURE THAT SAFETY GLASSES AND HIGH TEMPERATURE GLOVES (PART# 62752) ARE WORN AT ALL TIMES WHEN OPERATING THE PROBILT SERIES HOT MELT UNIT.



FAILURE TO RELIEVE SYSTEM PRESSURE CAN RESULT IN SERIOUS BURNS. SYSTEM PRESSURE MUST BE RELIEVED BEFORE:

- REMOVING THE ADHESIVE FILTER
- OPENING THE MANIFOLD DRAIN VALVE
- REMOVING A NOZZLE



HOT MELT GUNS ARE ALWAYS HOT DURING OPERATION. MAKE SURE GUNS ARE NEVER TOUCHED DURING THIS TIME.



THE PROBILT SERIES HOT MELT UNIT, HOSES AND GUNS CONTAIN POTENTIALLY FATAL ENERGIZED ELECTRICAL COMPONENTS. ONLY QUALIFIED PERSONNEL SHOULD BE OPERATING THIS EQUIPMENT.

DO NOT ACTIVATE OR TRIGGER GUNS WITH COLD MATERIAL. DAMAGE WILL RESULT TO THE SEALS AND SEATS.

START - UP PREPARATION

1. Shut **OFF** air pressure to the pump.
2. Make sure electrical input is **ON** and then turn **ON** the tank circuit breaker (handle is in the up position when **ON**) and verify that the green power lamp is glowing.
3. Open the tank lid and add hot melt adhesive to within one inch of the top of the tank.
4. Close the tank lid.
5. If you have not already done so, program your unit.

SEE "SECTION 5" TO PROGRAM THE UNIT

6. As stated in Section 1 and 2, the enabled tank and hose zones will begin heating first. Once setpoint temperature has been reached on those zones (approximately 30-45 minutes), the gun zones will begin heating. When all enabled zones have reached setpoint temperature, the "HEAT ON/ZONE STATUS" LED will be flashing for all zones as the units scans, signaling that the unit is ready to run.
7. Open the drain valve located in the lower right hand corner in the front of the unit, next to the filter assembly, by slowly turning the slotted screw counter clockwise.

SEE "FIGURE 9" FOR LOCATION OF THE DRAIN VALVE

8. Begin to pressurize the pump by slowly opening the air filter regulator located to the right of the tank, just above the hose connections. This will allow any trapped air in the manifold to be removed as hot melt begins to flow.
9. When all air has been removed, close the drain valve.
10. Next, trigger all guns until trapped air is out of the system.
11. Universal Systems recommends a minimum 20-35 psi input air pressure to the pump and a minimum 45-55 psi to all gun solenoid valves.

DEPENDING ON THE HOT MELT ADHESIVE BEING USED, AIR PRESSURE MAY NEED TO BE ADJUSTED TO MEET THE REQUIREMENTS OF THE APPLICATION.

12. Always maintain a half full level of melted adhesive in the tank to avoid a pressure drop in the pump and a charring effect on the tank surface.
13. Continue to refill periodically to within 1 inch of the top of the tank.

DO NOT OVERFILL THE TANK.

STANDBY MODE

1. To place the unit into standby mode, simply press the "SETBACK" key. The amber LED will begin to glow and all zones will drop and hold a setpoint temperature of 165°F.
2. To remove the unit from standby mode, press the "SETBACK" key. The amber LED will turn **OFF** and all enabled zones will heat to their preselected setpoint temperatures.

SECTION 7 – MAINTENANCE GUIDELINES

INTRODUCTION

The PROBILT SERIES hot melt unit has been designed for durability and high performance without requiring an extensive amount of preventative maintenance. Periodically following the guidelines below will help insure your PROBILT SERIES hot melt unit a trouble free performance.

PREVENTATIVE MAINTENANCE

- Keep the applicator, hoses, and guns clean.
- Check the tank filter (PART# B100-096) periodically, based on your operating experience with your adhesive. Universal Systems recommends checking every 2 – 3 weeks, based on normal usage.
- Check in-line filters periodically and change as needed. The filter assembly is located between the hose and the gun. Universal Systems strongly recommends in-line filters are used at all times.

VISIT www.USSEFL.com FOR INFORMATION ABOUT IN-LINE FILTERS

- Check glue guns for clogged nozzles. Change as needed.

FILTER CHANGE

For a fast, easy filter change, a complete filter assembly (PART# B100-275) is recommended as a spare part.

TO PREVENT INJURY AND BURNS FROM HOT MELT ADHESIVE, HOT PARTS, AND HOT APPLICATION SURFACES, ALWAYS BE SURE TO WEAR SAFETY GOGGLES, SAFETY GLOVES, AND PROTECTIVE CLOTHING.



1. The hot melt system must be at operating temperature before the filter assembly can be removed.
2. Reduce input air pressure to zero at the air regulator. Trigger guns to relieve system pressure.



FAILURE TO RELIEVE SYSTEM PRESSURE CAN RESULT IN SERIOUS BURNS WHEN FILTER IS LOOSENED.

3. Place a metal container under the drain valve and proceed to open valve. Slowly increase pump air pressure until a steady flow of adhesive is observed.
4. Once clean hot melt adhesive is seen flowing from the valve, reduce air pressure to zero and close the valve.
5. Unscrew the filter assembly and remove from the manifold.

6. Disassemble the filter assembly by removing the screw, filter screen, and core.

SEE "FIGURE 4" FOR FILTER ASSEMBLY DETAILS

7. Replace the o-ring (PART# 6117) and slide the replacement filter screen (PART# B100-096) over the core. Insert and tighten the screw.
8. Screw the filter assembly into the manifold.

VERIFY THAT THE APPLICATOR IS AT FULL TEMPERATURE AND THEN TIGHTEN.

SYSTEM CLEANING

Due to excessive debris and charred material collecting throughout the PROBILT SERIES hot melt unit, periodically the systems must be flushed.

SEE "FIGURE 17" FOR PURGE PLUS HOT MELT ADHESIVE CLEANER AND CLEANING PROCEDURES

SECTION 8 – TROUBLESHOOTING

INTRODUCTION

The following information is troubleshooting guidelines designed to correct fault conditions that may occur with the PROBILT SERIES hot melt unit.

IF A PROBLEM OCCURS WITH THE PROBILT SERIES HOT MELT UNIT, IMMEDIATELY CONTACT UNIVERSAL SYSTEMS BEFORE TRYING TO SERVICE THE UNIT YOURSELF.

- Universal Systems trained personnel are readily available to help you if you are having a problem with your hot melt unit.
- **Only qualified personnel should attempt to service the PROBILT SERIES hot melt unit.** Even qualified personnel must consult with a Universal Systems technician before attempting service.



BEFORE REMOVING ANY CABINET PANELS FOR TROUBLESHOOTING OR DISASSEMBLY, BE CERTAIN EXTERNAL POWER HAS BEEN DISCONNECTED.

SEE "SECTIONS 1 & 4" FOR PROPER SAFETY PROCEDURES

SERVICE

UNIVERSAL SYSTEMS IS THE ONLY AUTHORIZED REPAIR CENTER FOR THE PROBILT SERIES HOT MELT UNIT.

SERVICE PERFORMED BY UNAUTHORIZED PERSONNEL MAY RESULT IN MISPLACING OF INTERNAL WIRES AND COMPONENTS, WHICH COULD CAUSE SERIOUS HAZARD AND FATAL INJURY. IN ADDITION, IMPROPER SERVICE TO THE UNIT MAY RESULT IN THE VOIDING OF WARRANTIES.

Contact the Universal Systems Customer Service Center at 1-800-848-5018 Toll Free within U.S.A. or +1-561-272-5442 for International Dialing, Monday through Friday between 8:30AM and 5:00PM E.S.T. for further information.

OVERVIEW OF LED INDICATORS

NORMAL SYSTEMS CONDITIONS

- ZONE LED'S

When an enabled zone (hose, gun or tank) is being displayed, either through AccuScan™ or manual "ZONE" key, the corresponding LED will glow solid green, indicating that the zone is "**ON**". If a zone LED does not glow when scanned, it is disabled and the 4 digit display will read "**OFF**".

- HEAT ON/ZONE STATUS LED

When an enabled zone is displayed, the “HEAT ON/ZONE STATUS” led will glow solid green if the zone is calling for heat; flashing green if the zone is at setpoint temperature; and will not be glowing if the zone is slightly over setpoint temperature (approximately +2°F) or disabled (“**OFF**”).

- SETBACK LED

When the “SETBACK” key is pressed, the LED will glow amber to indicate the system is in standby mode.

Setback temperature is 165°F. All enabled zones will default to 165°F.

ABNORMAL SYSTEM CONDITIONS

- FAULT ALARM LED

The following two fault conditions will cause the “ALARM” LED to glow red. The system’s audible alarm will sound and the EFA will signal any connected visual or audible alarm.

- CONDITION 1 - **rtdH**

Problem: An RTD of a component in any enabled zone has shorted or is open.

Solution: Replace either the RTD of the zone component or the component itself (ie: hose or gun).

- CONDITION 2 - **HtrL**

Problem: A heater or heater circuit of a component of any enabled zone has failed.

Solution: Replace either the heater of the zone component or the component itself (ie: hose, gun or control board)

PISTON PUMP TROUBLESHOOTING

CONDITION	POSSIBLE CAUSE	SOLUTIONS
PUMP FAILS TO STROKE	ADHESIVE NOT SUFFICIENTLY HEATED	CHECK TANK TEMPERATURE SETTING AND ADJUST IF NECESSARY
	INADEQUATE OR NO INPUT AIR TO PUMP	INCREASE AIR FROM PLANT AIR SUPPLY SEE "SECTION 4" FOR AIR PRESSURE REQUIREMENTS
	TANK FILTER CLOGGED	REPLACE TANK FILTER SEE "SECTION 7" FOR TANK FILTER REPLACEMENT
	CLOGGED GUN NOZZLE	REPLACE NOZZLE.
	COLD TANK, HOSE, OR GUN	SEE PAGES 38-39 FOR TANK/HOSE/GUN FAILS TO HEAT
	FAULTY SHIFTER	REPLACE SHIFTER (B100-816) SEE "SECTION 9" FOR SHIFTER REPLACEMENT
	HYDRAULIC SECTION FAILURE CAUSED BY CONTAMINENTS	REPLACE PUMP ASSEMBLY (PART# C100-565) SEE "SECTION 9" FOR PUMP REPLACEMENT
	PUMP SOLENOID NOT ON	TANK NOT WITHIN 35°F OF SETPOINT TEMPERATURE
	FAILED PUMP SOLENOID	REPLACE PUMP SOLENOID
PUMP STROKES TOO RAPIDLY	ADHESIVE NOT SUFFICIENTLY HEATED	CHECK TANK TEMPERATURE SETTING AND ADJUST IF NECESSARY
	EXCESSIVE AIR PRESSURE TO PUMP	REDUCE AIR PRESSURE AT REGULATOR ON PUMP
	ADHESIVE LEVEL IN TANK TOO LOW	REFILL HOT MELT TANK
	TANK RELIEF VALVE BLOCKED (OPEN)	REPLACE VALVE (PART# A100-208) SEE "SECTION 9" FOR PUMP REPLACEMENT
	BALL CHECK COMPONENTS CLOGGED WITH CHAR OR CONTAMINENTS	REPLACE PUMP ASSEMBLY (PART# C100-565) SEE "SECTION 9" FOR PUMP REPLACEMENT

TANK HEATER TROUBLESHOOTING

CONDITION	POSSIBLE CAUSE	SOLUTIONS
TANK FAILS TO HEAT OR UNDERHEATS	TANK ZONE IF "OFF"	TURN TANK ZONE "ON" SEE "SECTION 5" FOR CONTROL PANEL OPERATION
	FAILED IN-LINE FUSE	REPLACE FUSE (PART# A100-262)
	INCORRECT INPUT WIRING, FAILED SINGLE-PHASE JUMPER	CHECK AND REPLACE JUMPER (PART# A100-259) SEE "FIGURE 8" FOR HOSE JUMPER DETAIL
TANK FAILS TO HEAT, UNDERHEATS, OR OVERHEATS	FAILED TANK HEATER	CALL UNIVERSAL SYSTEMS
	INCORRECT CONTROLLER SETTING	ADJUST CONTROLLER
	FAILED TANK RTD	REPLACE RTD (PART# A100-274) SEE "SECTION 9" FOR RTD REPLACEMENT
	FAILED TANK TRIAC	REPLACE TRIAC (PART# A100-271) SEE "SECTION 9" FOR TRIAC REPLACEMENT
	FAILED CONTROL BOARD	REPLACE CONTROL SYSTEM PANEL ASSEMBLY (PART# C100-568) SEE "SECTION 9" FOR CONTROL PANEL REMOVAL

HOSE TROUBLESHOOTING

CONDITION	POSSIBLE CAUSE	SOLUTIONS
HOSE FAILS TO HEAT OR UNDERHEATS	HOSE ZONE IF "OFF"	TURN HOSE ZONE "ON" SEE "SECTION 5" FOR CONTROL PANEL OPERATION
	INCORRECT CONTROLLER SETTING	ADJUST CONTROLLER
	CONNECTOR LOOSE AT APPLICATOR	CHECK AND SNAP TIGHT
	FAILED HOSE HEATER	REPLACE HOSE
	FAILED HOSE RTD	REPLACE HOSE
	FAILED CONTROL BOARD FUSES	CHECK AND REPLACE FUSES (PART# A100-278)
	FAILED CONTROL BOARD	REPLACE CONTROL SYSTEM PANEL ASSEMBLY (PART# C100-568) SEE "SECTION 9" FOR CONTROL PANEL REPLACEMENT

GUN TROUBLESHOOTING

CONDITION	POSSIBLE CAUSE	SOLUTIONS
GUN FAILS TO HEAT OR UNDER HEATS	GUN ZONE IF "OFF"	TURN GUN ZONE "ON" SEE "SECTION 5" FOR CONTROL PANEL OPERATION
	INCORRECT CONTROLLER SETTING	ADJUST CONTROLLER
	CONNECTOR LOOSE AT APPLICATOR	CHECK AND SNAP TIGHT
	FAILED GUN HEATER	REPLACE GUN
	FAILED GUN RTD	REPLACE GUN
	FAILED CONTROL BOARD FUSES	CHECK AND REPLACE FUSES (PART# A100-278)
	FAILED CONTROL BOARD	REPLACE CONTROL SYSTEM PANEL ASSEMBLY (PART# C100-568) SEE "SECTION 9" FOR CONTROL PANEL REMOVAL

CIRCUIT BREAKER TROUBLESHOOTING

CONDITION	POSSIBLE CAUSE	SOLUTIONS
CIRCUIT BREAKER WILL NOT STAY ON	FAILED RTD CAUSING TANK TO OVERHEAT	REPLACE RTD (PART# A100-274) SEE "SECTION 9" FOR RTD REPLACEMENT
	TANK THERMOSTAT CLOSED	REPLACE THERMOSTAT (PART# A100-273) SEE "SECTION 9" FOR THERMOSTAT REPLACEMENT
	CIRCUIT BREAKER FAILED	REPLACE CIRCUIT BREAKER (PART# A100-261) SEE "SECTION 9" CIRCUIT BREAKER REPLACEMENT

HOT MELT ADHESIVE TROUBLESHOOTING

CONDITION	POSSIBLE CAUSE	SOLUTIONS
ADHESIVE SPITTING WHEN FIRED	ADHESIVE OUTPUT IS GREATER THAN THE DELIVERY RATE OF SYSTEM	REDUCE OUTPUT TO A MAXIMUM OF 10 POUNDS PER HOUR
	PUMP AIR PRESSURE SET BELOW RECOMMENDED MINIMUM PUMP AIR PRESSURE	INCREASE PUMP AIR PRESSURE TO A MINIMUM OF 20PSI
	ADHESIVE NOT SUFFICIENTLY HEATED	INCREASE TANK TEMPERATURE AS NEEDED
	GLUE LEVEL IN TANK IS LOW OR TANK IS EMPTY	REFIL GLUE IN TANK AS REQUIRED
WAVINESS IN BEAD DEPOST	ADHESIVE NOT SUFFICIENTLY HEATED	INCREASE TANK TEMPERATURE AS NEEDED
	AMBIENT TEMPERATURE IS BELOW 32°F	INCREASE AMBIENT TEMPERATURE
	NOZZLE(S) EXPOSED TO DRAFT	ELIMINATE DRAFT
	GUN TEMPERATURE IS TOO LOW	INCREASE GUN TEMPERATURE AS NEEDED
	NOZZLE(S) TOO FAR FROM SUBSTRATE	MOVE GUN INTO POSITION SO THE NOZZLE(S) ARE .050 INCHES AWAY FROM SUBSTRATE
EXCESSIVE ADHESIVE AT BEGINNING OF BEAD	NOZZLE(S) TOO FAR FROM SUBSTRATE	MOVE GUN INTO POSITION SO THE NOZZLE(S) ARE .050 INCHES AWAY FROM SUBSTRATE
	CLOGGED NOZZLE	CLEAN OR REPLACE NOZZLE
	GUN AIR PRESSURE SET TOO LOW	INCREASE AIR PRESSURE TO THE GUN AS NEEDED (MINIMUM 35PSI FOR 200 SERIES GUNS AND MINIMUM 60PSI FOR 400 SERIES GUNS)
	PUMP AIR PRESSURE SET TOO HIGH	DECREASE PUMP AIR PRESSURE AS NEEDED
	NOZZLE ORIFICE SIZE TOO LARGE	CHANGE TO A NOZZLE WITH A SMALLER ORIFICE SIZE
EXCESSIVE ADHESIVE AT END OF BEAD	PUMP AIR PRESSURE SET TOO LOW	INCREASE PUMP AIR PRESSURE AS NEEDED
	ADHESIVE NOT SUFFICIENTLY HEATED	INCREASE TANK TEMPERATURE AS NEEDED
	GUN AIR PRESSURE SET TOO LOW	INCREASE AIR PRESSURE TO THE GUN AS NEEDED (MINIMUM 35PSI FOR 200 SERIES GUNS AND MINIMUM 60PSI FOR 400 SERIES GUNS)
ADHESIVE STRINGING AT CUT-OFF	NOZZLE(S) TOO FAR FROM SUBSTRATE	MOVE GUN INTO POSITION SO THE NOZZLE(S) ARE .050 INCHES AWAY FROM SUBSTRATE
	ADHESIVE IS TOO VISCOUS	SLIGHTLY INCREASE TANK TEMPERATURE OR CHANGE TO AN ADHESIVE WITH A LOWER VISCOSITY
	ADHESIVE NOT SUFFICIENTLY HEATED	INCREASE TANK TEMPERATURE AS NEEDED
	GUN SPEED TOO SLOW	DECREASE THE DISTANCE BETWEEN THE SOLENOID VALVE AND GUN, USE AN AIR-PILOTED RELAY VALVE BETWEEN SOLENOID AND GUN OR USE A FASTER-ACTING GUN
	ADHESIVE IS TOO OLD	DRAIN ALL ADHESIVE FROM TANK AND REFIL WITH FRESH ADHESIVE
	GUN TEMPERATURE IS TOO LOW	INCREASE GUN TEMPERATURE AS NEEDED

<p>ADHESIVE DROOLING FROM GUN</p> <hr/> <p>UNEQUAL STREAMS OF GLUE WHEN FIRING A MULTI-MODULE GUN</p>	<p>SPRING TENSION OF THE GUN MODULE(S) SET TOO LOW</p> <hr/> <p>PISTON OR SEAT OF GUN MODULE(S) CLOGGED OR DAMAGED NOZZLES ON THE GUN MODULES ARE DIFFERENT SIZES SPRING TENSION ON THE GUN MODULES IS UNEQUAL</p> <p>CLOGGED OR DAMAGED NOZZLES ON THE GUN MODULES</p> <p>CHAR OR OTHER CONTAMINATION IN GUN MODULES</p> <p>AIR PRESSURE TO GUN TOO LOW OR UNEQUAL AIR PRESSURE TO GUNS</p> <p>HYDRAULIC PRESSURE NOT EQUAL AT GUNS</p> <p>AIR CHAMBER OF THE GUN MODULE CONTAINS ADHESIVE</p>	<p>ADJUST SPRING TENSION AS REQUIRED</p> <hr/> <p>CLEAN OR REPLACE MODULES</p> <p>INSTALL THE SAME SIZE NOZZLE ON ALL GUN MODULES ADJUST SPRING TENSION AS REQUIRED</p> <p>CLEAN OR REPLACE NOZZLES</p> <p>CLEAN OR REPLACE GUN MODULES</p> <p>ADJUST AIR PRESSURE AS NEEDED</p> <p>ADJUST NOZZLE SIZE OR GUN DISTANCE FROM THE SUBSTRATE TO COMPENSATE FOR THE DIFFERENCE</p> <p>REPLACE MODULE</p>
<p>ADHESIVE BOUNCING OR SPLASHING FROM SUBSTRATE</p>	<p>ADHESIVE IS TOO HOT</p> <p>PUMP AIR PRESSURE SET TOO HIGH</p> <p>ADHESIVE VISCOSITY TOO LOW</p> <p>NOZZLE ORIFICE SIZE TOO SMALL</p>	<p>DECREASE TEMPERATURE TO THE POT AS NEEDED</p> <p>DECREASE PUMP AIR PRESSURE AS NEEDED</p> <p>DECREASE TEMPERATURE TO THE POT AS NEEDED OR SWITCH TO AN ADHESIVE WITH A HIGHER VISCOSITY</p> <p>SWITCH TO A NOZZLE WITH A SMALLER ORIFICE SIZE</p>
<p>ADHESIVE NOT STICKING TO SUBSTRATE</p>	<p>ADHESIVE NOT HOT ENOUGH</p> <p>SPECIAL COATING ON THE SUBSTRATE</p> <p>NOT ENOUGH ADHESIVE BEING APPLIED</p> <p>ADHESIVE VISCOSITY TOO HIGH</p>	<p>INCREASE TEMPERATURE AS NEEDED</p> <p>INCREASE TEMPERATURE AS NEEDED OR CONSULT ADHESIVE SUPPLIER FOR AN ADHESIVE COMPATIBLE WITH THE SUBSTRATE</p> <p>SWITCH TO A NOZZLE WITH A LARGER ORIFICE SIZE, INCREASE TEMPERATURE AS NEEDED OR INCREASE PUMP AIR PRESSURE</p> <p>INCREASE TEMPERATURE TO THE POT AS NEEDED OR SWITCH TO AN ADHESIVE WITH A LOWER VISCOSITY</p>
<p>CONTAINER OPENS AFTER LEAVING COMPRESSION</p>	<p>ADHESIVE NOT COOLING FAST ENOUGH</p>	<p>ANY OR ALL OF THE FOLLOWING MAY APPLY:</p> <p>DECREASE BEAD SIZE</p> <p>DECREASE TEMPERATURE TO THE POT AS NEEDED</p> <p>INCREASE DISTANCE BETWEEN THE NOZZLE AND THE SUBSTRATE</p> <p>INCREASE DISTANCE BETWEEN EXTRUSION OF ADHESIVE AND COMPRESSION</p> <p>INCREASE LENGTH OF COMPRESSION</p> <p>REDUCE LINE SPEED</p> <p>COOL THE SUBSTRATE</p>

<p>CONTAINER OPENS AFTER LEAVING COMPRESSION (CONT.)</p>	<p>ADHESIVE NOT COOLING FAST ENOUGH (CONT.)</p> <p>ADHESIVE BEING USED HAS TOO LONG OF AN OPEN TIME</p> <p>ADHESIVE COOLING TOO FAST</p> <p>ADHESIVE BEING USED HAS TOO SHORT OF AN OPEN TIME</p> <p>ADHESIVE DEPOSIT IS SHEARING</p> <p>COMPRESSIONS FORCE IS TOO LITTLE</p> <p>INSUFFICIENT HOT TACK</p>	<p>USE A NOZZLE WITH A SMALLER ORIFICE SIZE</p> <p>SWITCH TO A STITCHED BEAD PATTERN</p> <p>SWITCH TO AN ADHESIVE WITH A SHORTER OPEN TIME OR DECREASE TEMPERATURE TO THE POT AS NEEDED</p> <p>ANY OR ALL OF THE FOLLOWING MAY APPLY:</p> <p>INCREASE BEAD SIZE</p> <p>INCREASE TEMPERATURE TO THE POT AS NEEDED</p> <p>DECREASE DISTANCE BETWEEN THE NOZZLE AND THE SUBSTRATE</p> <p>DECREASE DISTANCE BETWEEN EXTRUSION OF ADHESIVE AND COMPRESSION</p> <p>HEAT THE SUBSTRATE</p> <p>USE A NOZZLE WITH A LARGER ORIFICE SIZE</p> <p>INCREASE BEAD LENGTH</p> <p>DO NOT USE A STITCHED BEAD PATTERN (IF APPLICABLE)</p> <p>PROTECT BEAD AND/OR GUN FROM COLD OR MOVING AIR</p> <p>SWITCH TO AN ADHESIVE WITH A LONGER OPEN TIME OR INCREASE TEMPERATURE TO THE POT AS NEEDED</p> <p>CHECK FOR TWISTING, COMPRESSION / RELAXING / MORE COMPRESSION OR OTHER ADVERSE MOVEMENT DURING COMPRESSION</p> <p>IF MOVEMENT THROUGH COMPRESSIONS IS SMOOTH, CHECK WITH ADHESIVE MANUFACTURER</p> <p>INCREASE COMPRESSION FORCE</p> <p>CHANGE ADHESIVE OR CHANGE BATCH OF CURRENT ADHESIVE</p>
--	--	--

SECTION 9 – PARTS AND COMPONENTS REPLACEMENT

INTRODUCTION

The PROBILT SERIES hot melt unit has been designed using a minimal number of components. The following information provides step-by-step instructions for a fast and easy replacement of any part or component that may have failed.

IF A PROBLEM OCCURS WITH THE PROBILT SERIES HOT MELT UNIT, IMMEDIATELY CONTACT UNIVERSAL SYSTEMS BEFORE TRYING TO SERVICE THE UNIT YOURSELF.

- Universal Systems trained personnel are readily available to help you if you are having a problem with your hot melt unit.
- **Only qualified personnel should attempt to service the PROBILT SERIES hot melt unit.** Even qualified personnel must consult with a Universal Systems technician before attempting service.



BEFORE REMOVING ANY CABINET PANELS FOR TROUBLESHOOTING OR DISASSEMBLY, BE CERTAIN EXTERNAL POWER HAS BEEN DISCONNECTED.

SEE "SECTIONS 1 & 4" FOR PROPER SAFETY PROCEDURES

SERVICE

UNIVERSAL SYSTEMS IS THE ONLY AUTHORIZED REPAIR CENTER FOR THE PROBILT SERIES HOT MELT UNIT.

SERVICE PERFORMED BY UNAUTHORIZED PERSONNEL MAY RESULT IN MISPLACING OF INTERNAL WIRES AND COMPONENTS, WHICH COULD CAUSE SERIOUS HAZARD AND FATAL INJURY. IN ADDITION, IMPROPER SERVICE TO THE UNIT MAY RESULT IN THE VOIDING OF WARRANTIES.

Contact the Universal Systems Customer Service Center at 1-800-848-5018 Toll Free within U.S.A. or +1-561-272-5442 for International Dialing, Monday through Friday between 8:30AM and 5:00PM E.S.T. for further information.

PUMP ASSEMBLY REPLACEMENT

1. Turn the circuit breaker on the front of the unit **OFF** once the applicator has reached normal application temperature.
2. Shut **OFF** input air to pump, set pump regulator to zero, and trigger all guns to relieve system pressure.
3. Remove pump cover and air regulator from pump.
4. Disconnect the tank to pump electrical plug.
5. Remove the three socket head screws and washers that secure the pump assembly to the tank.

SEE "FIGURE 9" FOR PUMP ASSEMBLY REMOVAL

6. Remove the entire pump assembly by rotating the pump slightly to break the suction and then pull straight up and out.

THE PUMP INLET, OUTLET, AND BLEED HOLE WILL CONTAIN HOT ADHESIVE THAT WILL FLOW FROM THE PUMP WHEN REMOVED. OBSERVE SAFETY PRECAUTIONS IN SECTION 1.

SEE "SECTION 1" FOR PROPER SAFETY PROCEDURES

7. To install the replacement pump assembly, position the crossover tube of the pump into the tank manifold inlet port.

SEE "FIGURE 7A & 7B" FOR INLET PORT DETAILS

8. Align the three bolt holes of the pump mount with the three holes in the tank. Insert the three socket head screws and washers that secure the pump assembly to the tank. Torque the screws 15-16 Ft-Lbs.
9. Connect the pump electrical plug to the tank receptacle.
10. Re-install the air regulator to the pump and connect the air input line. Activate air line.
11. Replace the pump cover and secure with the cover screw.
12. Resume normal operation, purging system of any air entrapped by triggering the guns.

PUMP SHIFTER REPLACEMENT

1. Before turning off glue unit, make sure pump shaft is bottomed out in the down position.
2. Turn the circuit breaker on the front of the unit **OFF**.
3. Reduce pump pressure to zero at regulator.
4. Remove pump cover and allow pump to cool down.
5. Disconnect the solenoid valve electrical plug. Remove the air line from the solenoid valve.

SEE "FIGURE 12" FOR PUMP SHIFTER ILLUSTRATION

6. Remove the two socket head screws that secure the shifter fork to the pump shaft, as well as the center set screw.
7. Remove the four socket head screws that secure the air valve assembly to the pump air motor.

DUE TO THE DESIGN, MANUFACTURING, AND ASSEMBLY PROCEDURE OF THE PUMP SHIFTER ASSEMBLY, UNIVERSAL SYSTEMS DOES NOT RECOMMEND DOING ANY TYPE OF REPAIR TO THE VALVE.

8. Remove the solenoid valve and affix to the new air valve assembly.
9. Attach the air valve assembly to the pump motor using the four socket head screws. Make sure that the new o-rings are in place. Do not tighten.
10. Attach the shifter fork bracket to the pump shaft using the two socket head cap screws and center set screw. Make sure that the shifter fork rests on the edge of the shaft.
11. Now tighten the four socket head screws to a torque of 65-75 In-Lbs.
12. Reconnect the air line to the solenoid valve. Connect the solenoid electrical plug to its receptacle.
13. Replace the pump cover and secure. Resume normal operation.

FILTER ASSEMBLY REPLACEMENT

SEE "SECTION 7" FOR TANK FILTER REPLACEMENT

CONTROL SYSTEM PANEL ASSEMBLY REPLACEMENT

1. Disconnect external power to the applicator. Even when the circuit breaker on the front of the PROBILT SERIES hot melt unit is turned **OFF**, the input terminals on the main circuit breaker will still be electrically charged if the unit is not disconnected from its outside power source.



THE BLACK HEAT SINKS ARE ELECTRICALLY CHARGED AND WILL GIVE OFF AN ELECTRICAL SHOCK IF TOUCHED WHEN THE CIRCUIT BREAKER IS ON.

2. Remove the control panel on the left side of the cabinet by unscrewing the four button head screws. Then, grasp the two control panel handles, tilt the panel forward, and pull up and out.

SEE "FIGURE 6" FOR REMOVAL OF THE ACCUSCAN™ CONTROL PANEL ASSEMBLY

3. Locate the green power plug at the J10 receptacle on the control board. Once the plug is located, carefully disconnect it from the board.

SEE "FIGURE 5A, 5B & 5C" FOR J7 POWER PLUG LOCATION

4. Locate the white tank plug at the J9 receptacle on the control board next to the J7 receptacle. Once the plug is located, carefully disconnect it from the board.
5. Disconnect the remaining hose/gun connector plugs from the control board receptacles J1, J4, J6 and J7. Please note their positions before disconnecting.
6. Lastly, disconnect the green EFA and PMI plugs from the control board only if these terminals have been wired for use.
7. The entire control panel assembly is now disconnected and can be removed.
8. Position the new control panel assembly in front of the open electrical enclosure and begin reconnecting the plugs to their corresponding control board receptacles as follows:

- HOSE/GUN PLUG 1 TO RECEPTACLE J1
- HOSE/GUN PLUG 2 TO RECEPTACLE J4
- HOSE/GUN PLUG 3 TO RECEPTACLE J6
- HOSE/GUN PLUG 4 TO RECEPTACLE J7
- WHITE 9-PIN PLUG TO RECEPTACLE J9
- GREEN 11-PIN PLUG TO RECEPTACLE J7
- GREEN EFA PLUG TO J2 - ALARM RECEPTACLE
- GREEN PMI PLUG TO J3 - PMI RECEPTACLE

9. Replace the control panel and secure with the four button head screws.

10. Restore external power to applicator and resume system.

SEE "SECTION 5" FOR SYSTEM PROGRAMMING PROCEDURES

TANK TRIAC REPLACEMENT

1. Disconnect external power to the applicator. Even when the circuit breaker on the front of the PROBILT SERIES hot melt unit is turned **OFF**, the input terminals on the main circuit breaker will still be electrically charged if the unit is not disconnected from its outside power source.



THE BLACK HEAT SINKS ARE ELECTRICALLY CHARGED AND WILL GIVE OFF AN ELECTRICAL SHOCK IF TOUCHED WHEN THE CIRCUIT BREAKER IS ON.

2. Remove the control panel on the left side of the cabinet by unscrewing the four button head screws. Then, grasp the two control panel handles, tilt the panel forward, and pull up and out.

3. SEE "FIGURE 6" FOR REMOVAL OF THE ACCUSCAN™ CONTROL PANEL ASSEMBLY

4. Locate the tank triac. Note the position of the wires that are attached to the triac and then disconnect the wires.

SEE "FIGURE 5A, 5B, 5C & 10" FOR TANK TRIAC AND WIRING DETAILS

5. Remove the failed triac from the unit and replace with the new triac using the two screws to screw it in place.
6. Reconnect the wires.

SEE "FIGURE 5A, 5B, 5C & 10" FOR TANK TRIAC AND WIRING DETAILS

7. Replace the control panel and secure with the four button head screws.
8. Restore electrical power to unit and resume system operation.

CIRCUIT BREAKER REPLACEMENT

1. Disconnect external power to the applicator. Even when the circuit breaker on the front of the PROBILT SERIES hot melt unit is turned **OFF**, the input terminals on the main circuit breaker will still be electrically charged if the unit is not disconnected from its outside power source.



THE BLACK HEAT SINKS ARE ELECTRICALLY CHARGED AND WILL GIVE OFF AN ELECTRICAL SHOCK IF TOUCHED WHEN THE CIRCUIT BREAKER IS ON.

2. Remove the control panel on the left side of the cabinet by unscrewing the four button head screws. Then, grasp the two control panel handles, tilt the panel forward, and pull up and out.

SEE "FIGURE 6" FOR REMOVAL OF THE ACCUSCAN™ CONTROL PANEL ASSEMBLY

3. To provide more working room, remove the four screws that secure the circuit breaker to the unit base **WITHOUT REMOVING THE WIRES**. Then pull the circuit breaker out from the electrical enclosure.
4. Note the position of all wires going to the circuit breaker. Remove all wires.

SEE "FIGURE 11" FOR CIRCUIT BREAKER WIRE POSITIONS

5. Attach the wires to the new circuit breaker. Failure to wire breaker correctly will cause the unit to malfunction and may cause circuit board failure.

SEE "FIGURE 11" FOR CIRCUIT BREAKER WIRE POSITIONS

6. Position the circuit breaker back into the unit base and secure with the four screws.
7. Replace the control panel and secure with the four button head screws.
8. Restore electrical power to unit and resume system operation.

TANK THERMOSTAT & TANK RTD REPLACEMENT

1. Disconnect external power to the applicator. Even when the circuit breaker on the front of the PROBILT SERIES hot melt unit is turned **OFF**, the input terminals on the main circuit breaker will still be electrically charged if the unit is not disconnected from its outside power source.
2. Remove the hose connector panel on the right side of the cabinet by unscrewing the four button head screws. This will enable access to the tank thermostat and RTD.

SEE "FIGURE 16" FOR TANK THERMOSTAT & RTD POSITIONS

3. Locate the small, square cut away in the tank insulation panel and remove, exposing both the tank thermostat and the tank RTD.
4. To replace the tank thermostat, remove the two screws that secure it to the tank. Disconnect the thermostat electrical plug from its receptacle, and remove. Attach the new thermostat to the tank and secure with the two screws. Reconnect the electrical plug into its receptacle.
5. To replace the tank RTD, remove the two screws in the plate that secure the RTD to the tank. Disconnect the RTD electrical plug from its receptacle, and remove. Apply heat sink compound to the new RTD and re-install RTD in its slot in the tank and secure with the plate and two screws. Reconnect the electrical plug to its receptacle.
6. Re-install the cutout of insulation.
7. Replace the hose connector panel and secure with the four button head screws.
8. Resume system operation.

SECTION 10 – FIGURE DRAWINGS

INTRODUCTION

The following pages contain the figure drawing referenced throughout Sections 1 – 9 in this manual.

Contact the Universal Systems Customer Service Center at 1-800-848-5018 Toll Free within U.S.A. or +1-561-272-5442 for International Dialing, Monday through Friday between 8:30AM and 5:00PM E.S.T. for further information on the figure drawings below or help with the information they are referenced to.

FIGURE 1A

PROBILT SERIES 8 HOT MELT UNIT
PART# D100-944

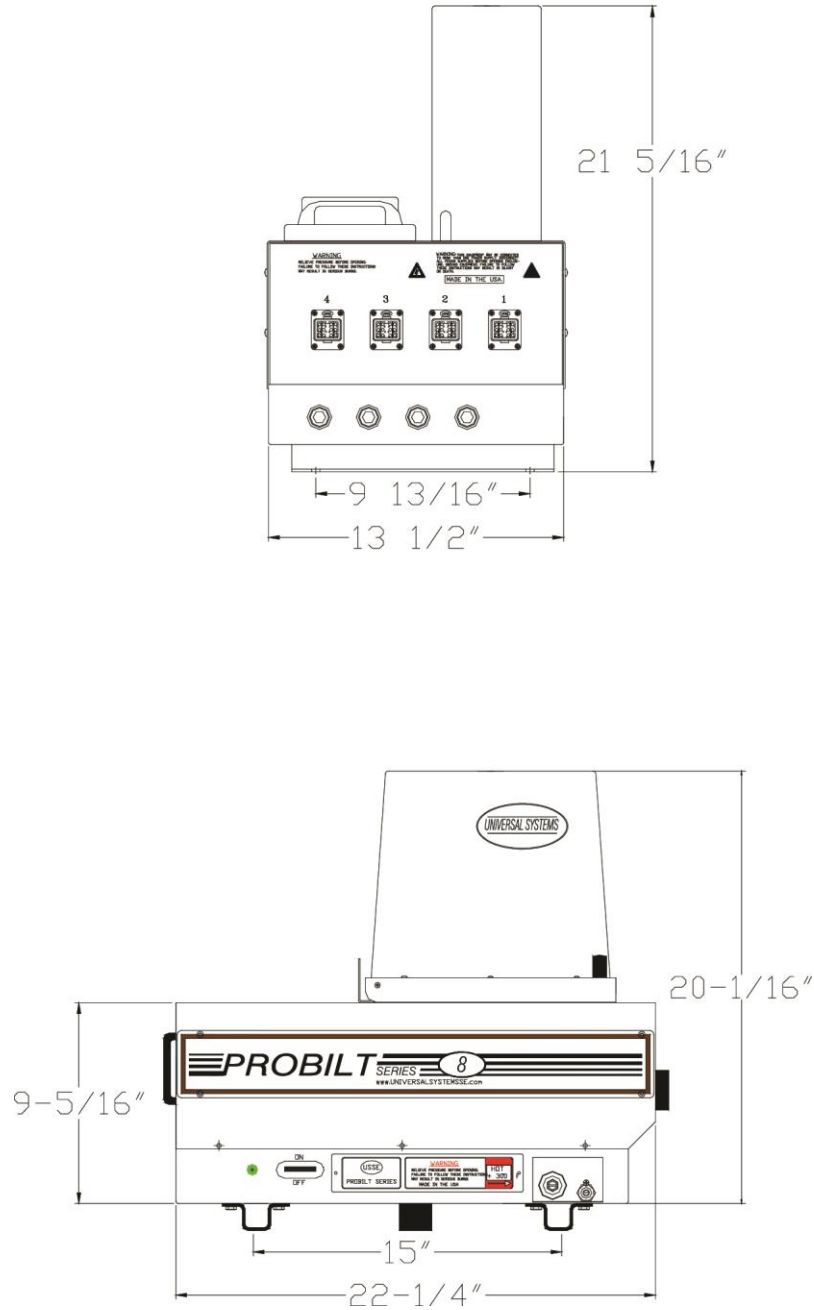

FIGURE 1B

PROBILT SERIES 15 HOT MELT UNIT
PART# D100-744

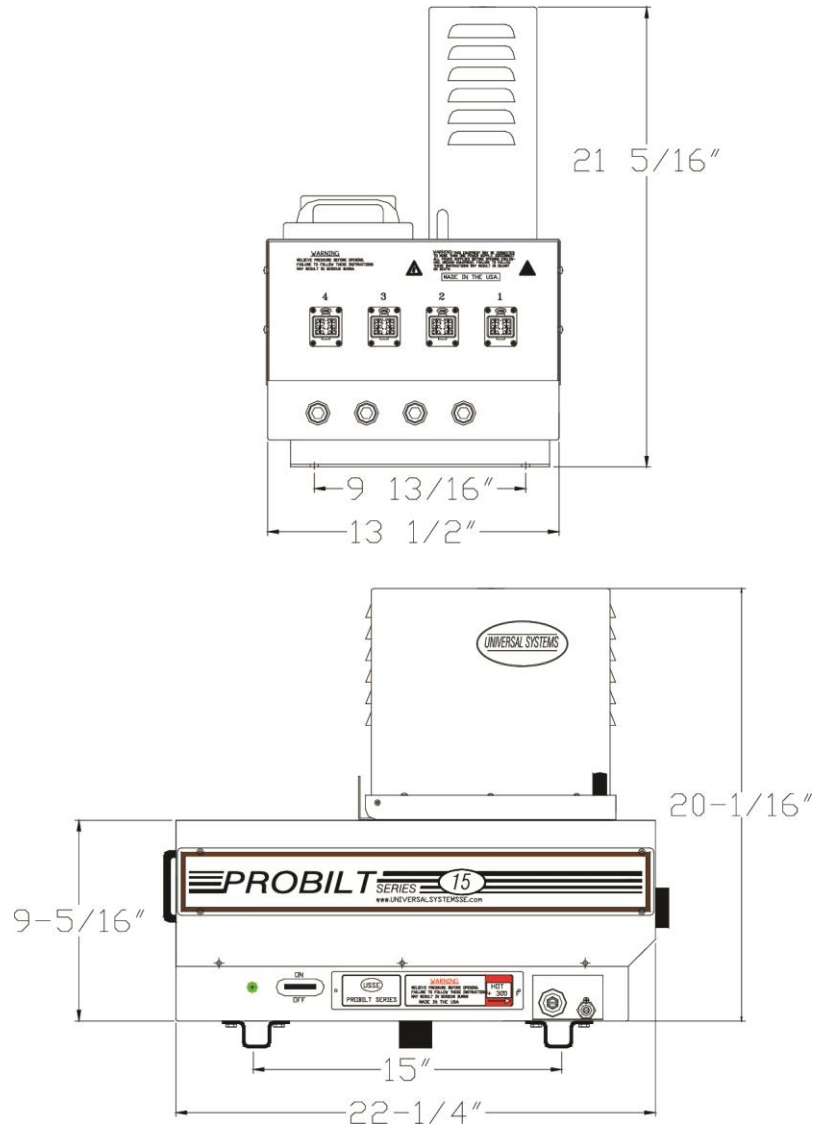

FIGURE 2

ACCUSCAN CONTROL SYSTEM
PART# C100-568



FIGURE 3

ACCUSET CONTROLLER

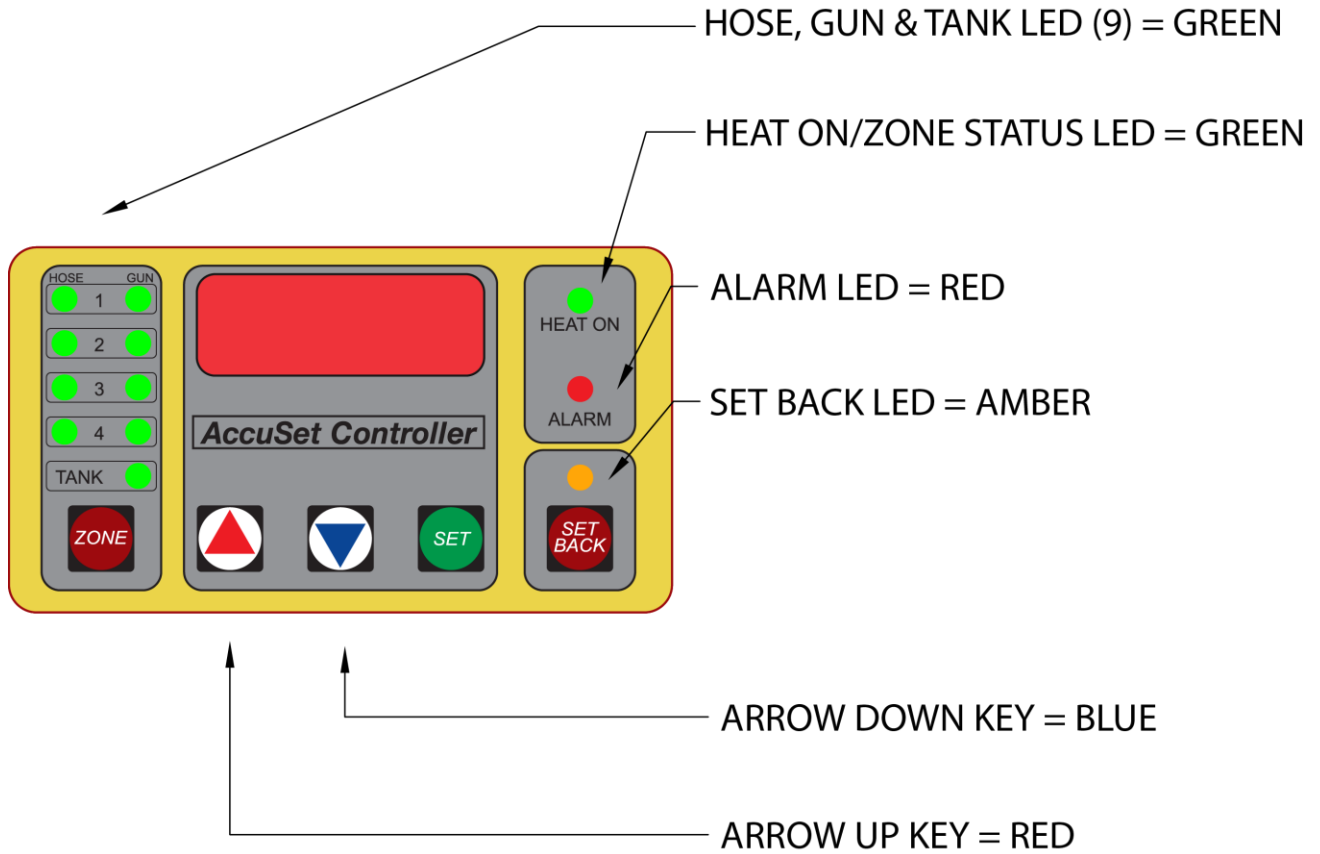

FIGURE 4

**TANK FILTER ASSEMBLY
PART# B100-275**

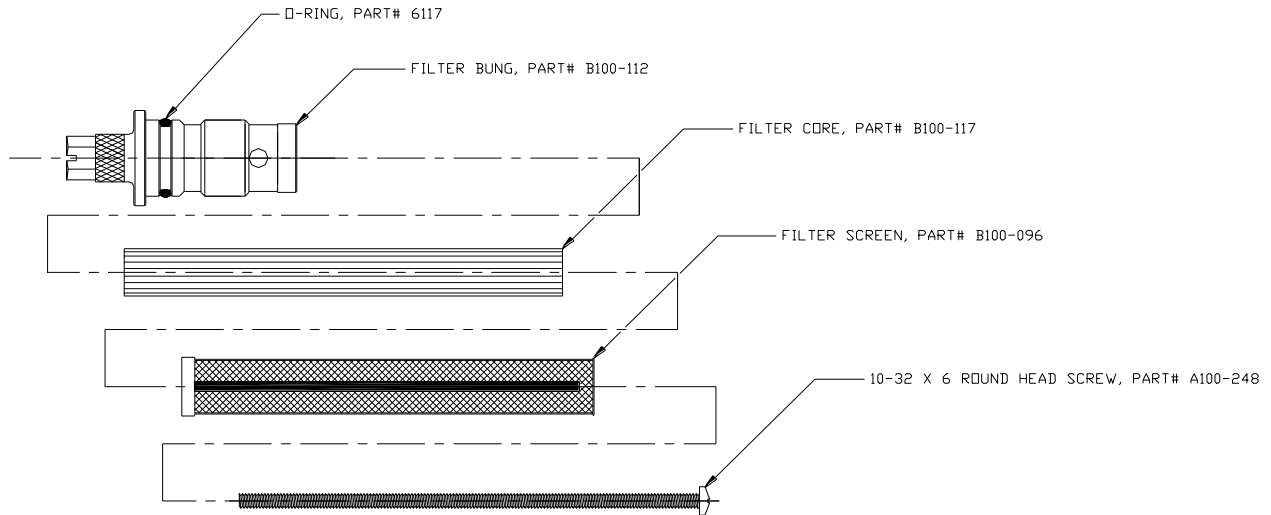

FIGURE 5A

TOP VIEW ELECTRICAL INSTALLATION (PROBILT SERIES 8)

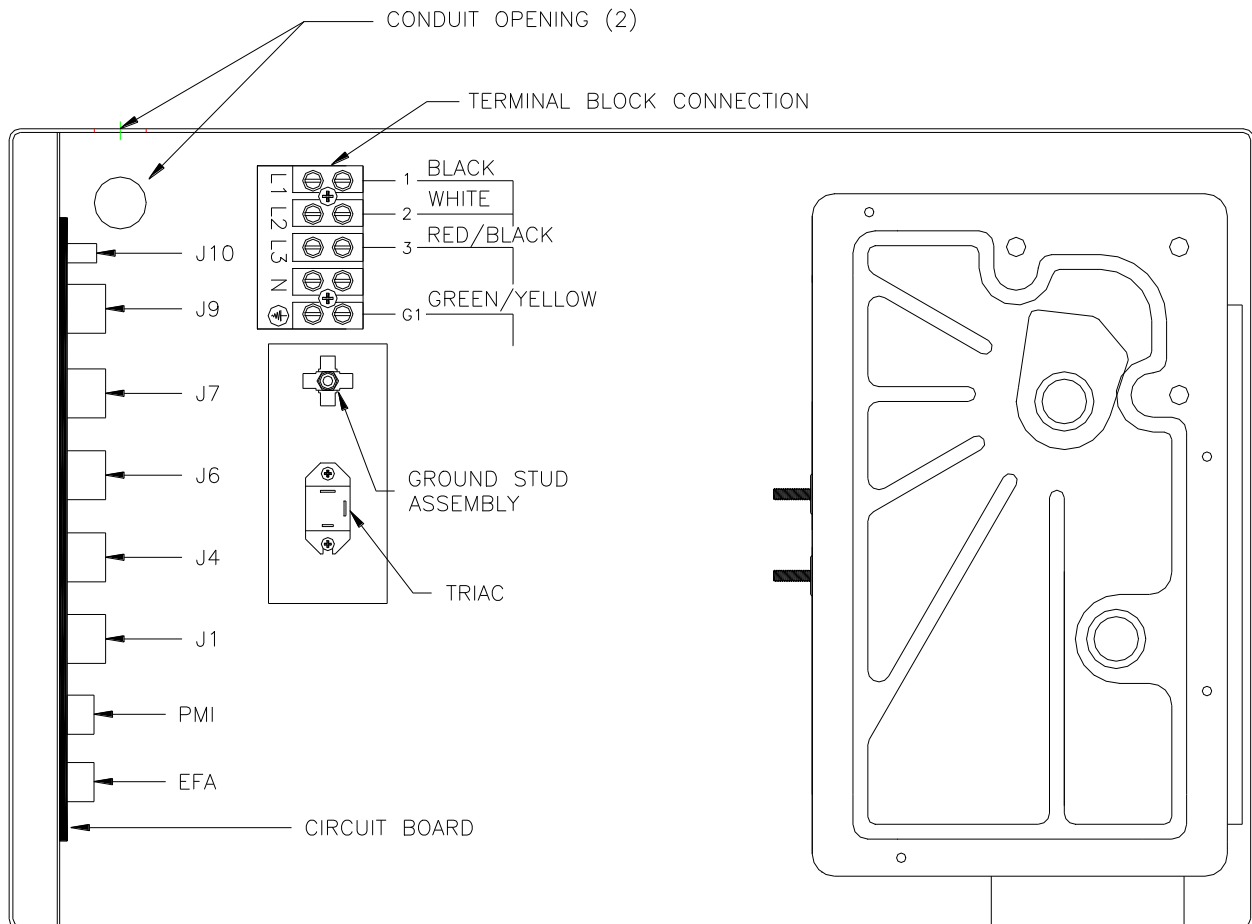

FIGURE 5B

TOP VIEW ELECTRICAL INSTALLATION (PROBILT SERIES 15)

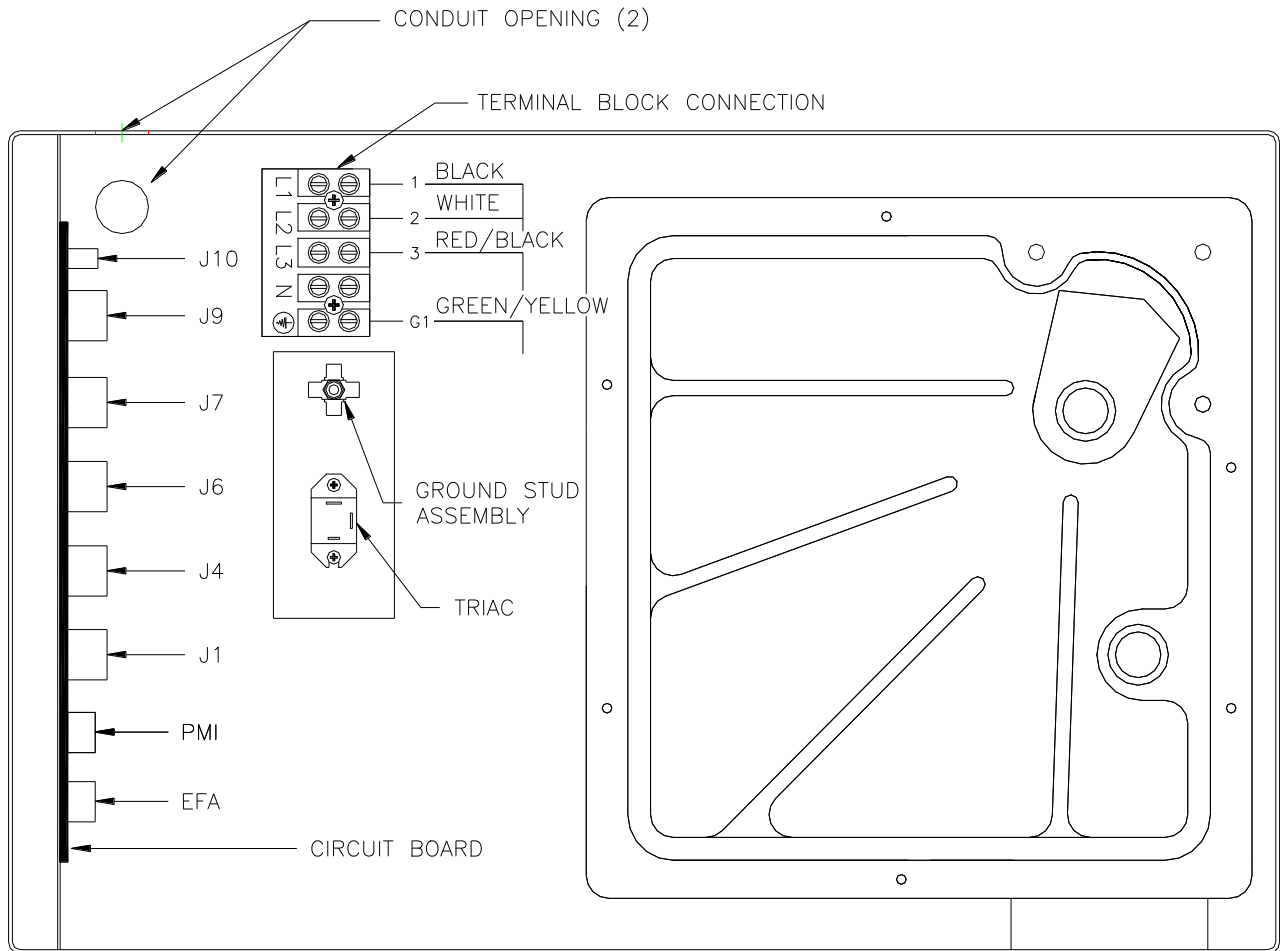

FIGURE 6

REMOVAL OF CONTROL PANEL ASSEMBLY

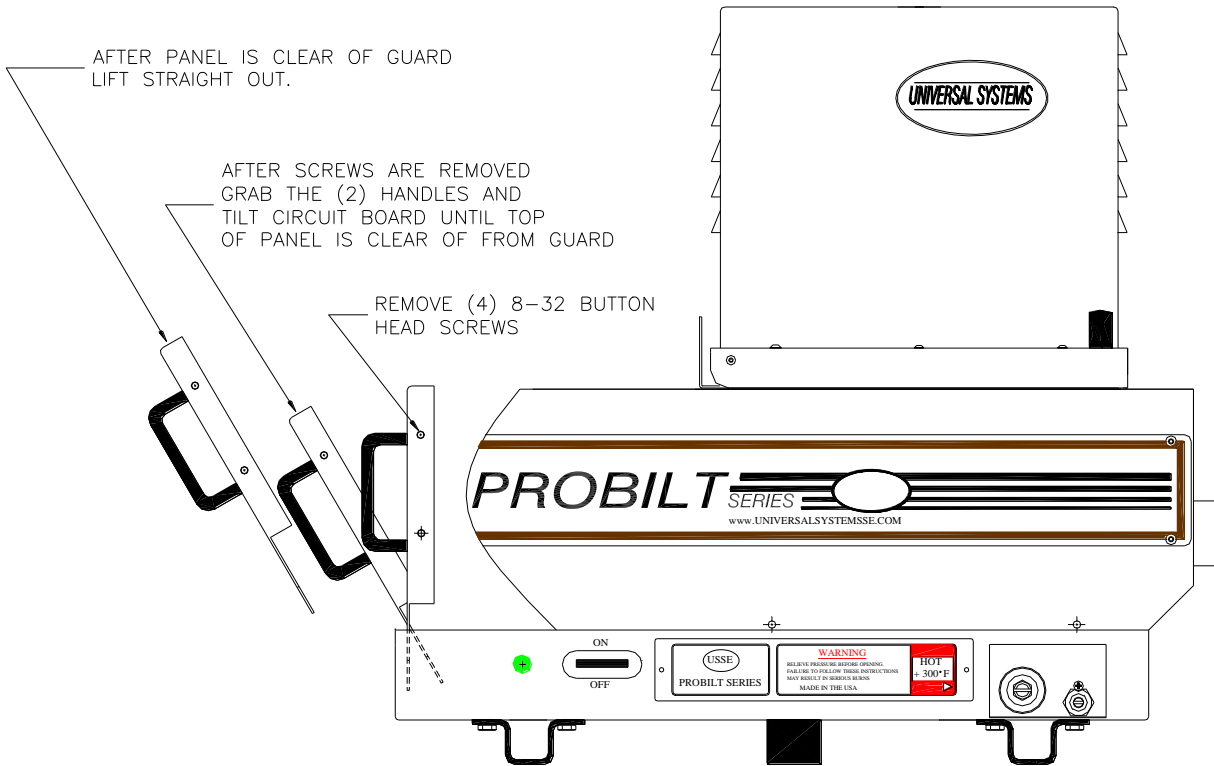

FIGURE 7

PUMP RECEPTICAL TOP VIEW (PROBILT SERIES 8 & 15)

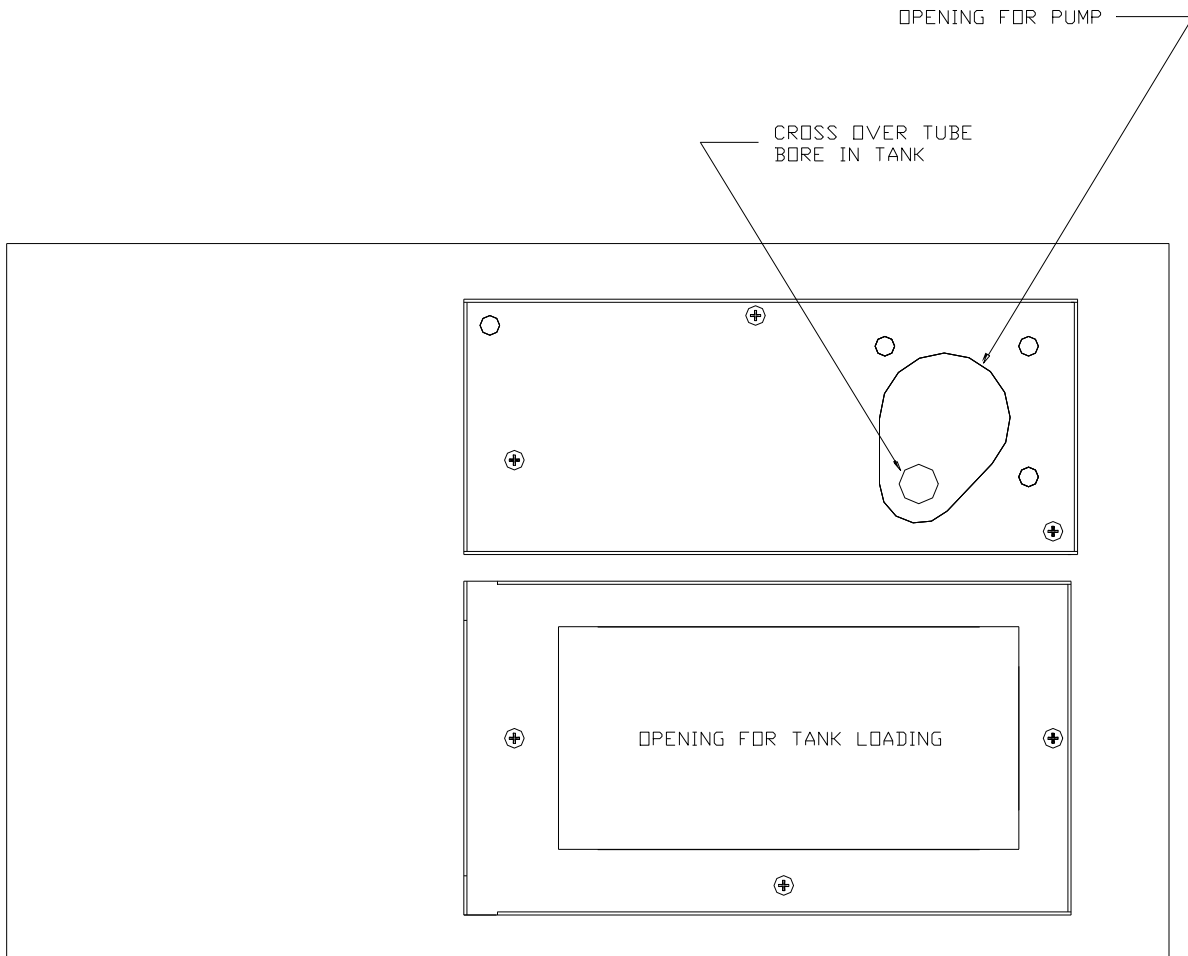

FIGURE 8

J7 CONNECTOR

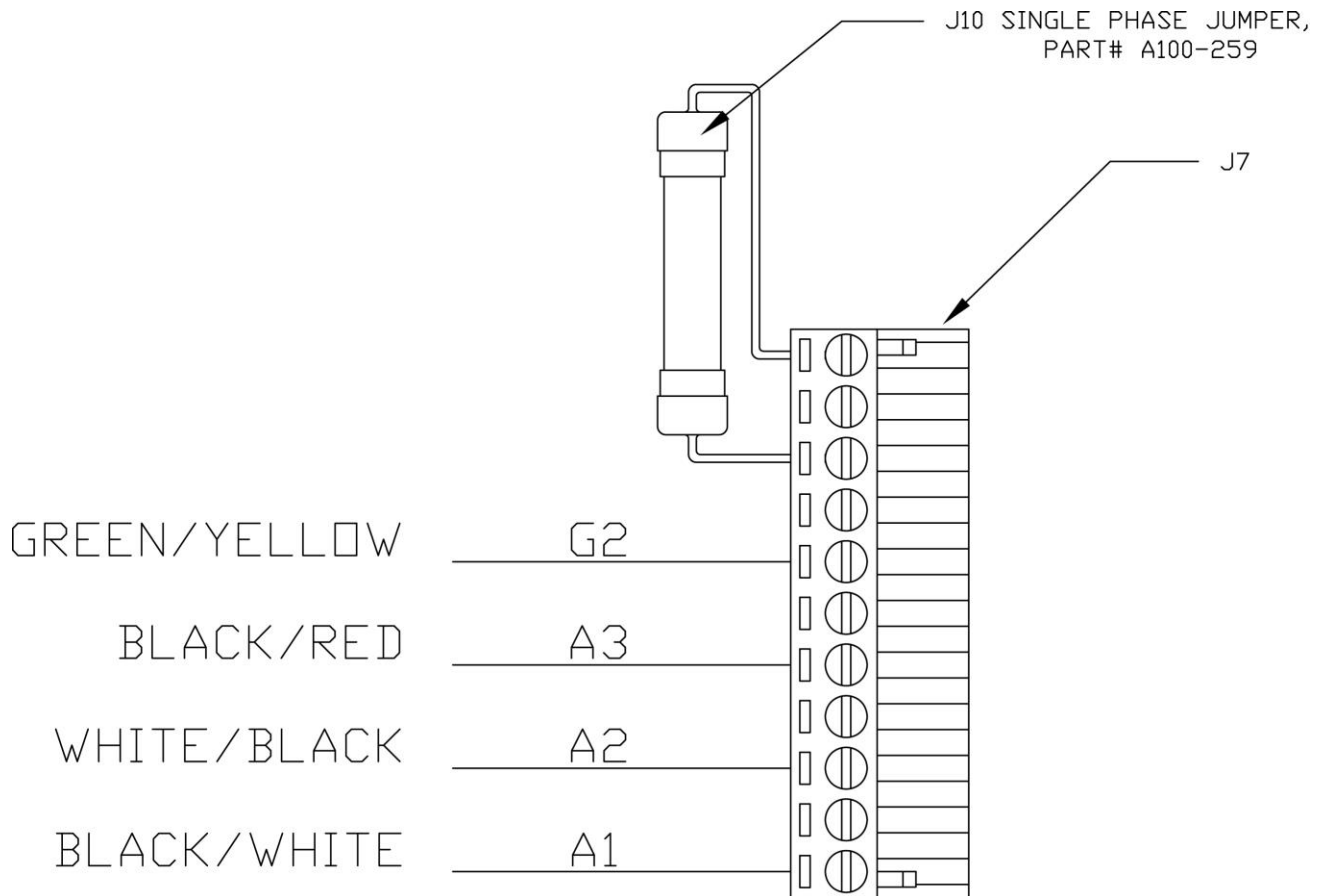

FIGURE 9

PUMP ASSEMBLY REMOVAL (PROBILT SERIES 8 & 15)

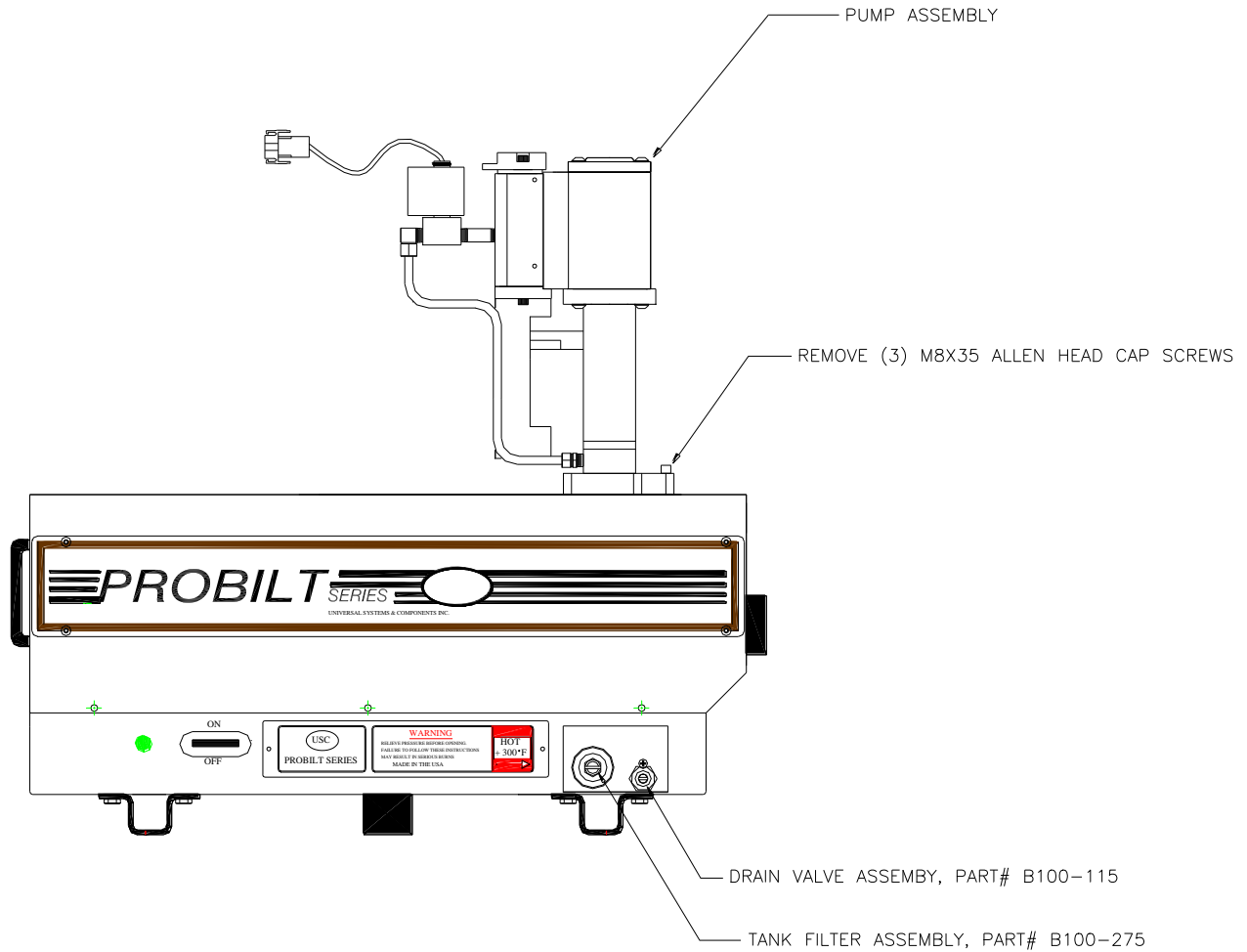

FIGURE 10

TANK TRIAC
PART# A100-271

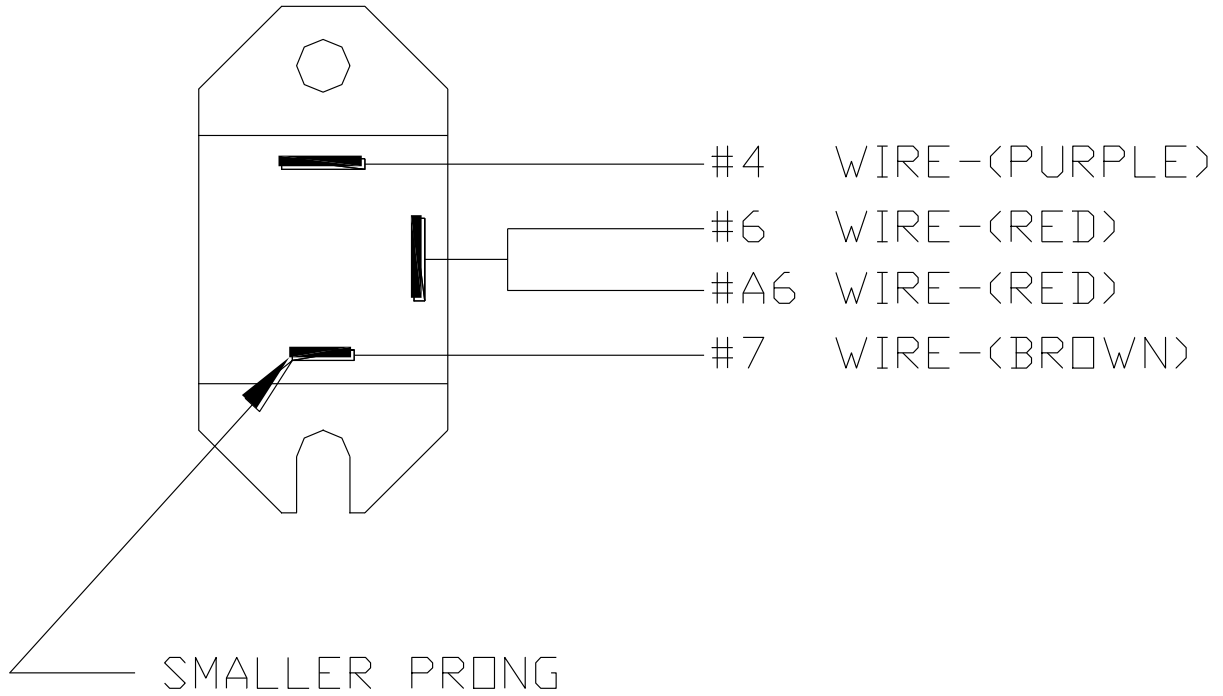

FIGURE 11

TANK CIRCUIT BREAKER
PART# A100-261

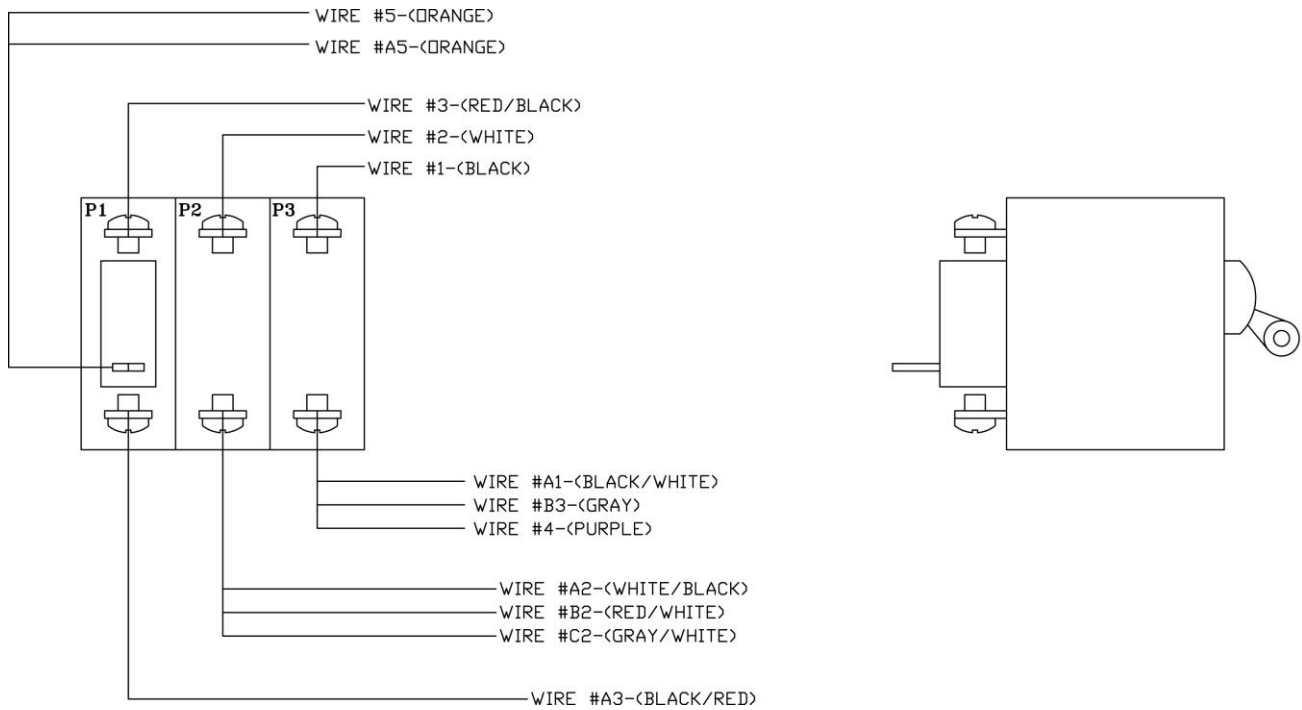

FIGURE 12

MP PUMP ASSEMBLY
PART# C100-565

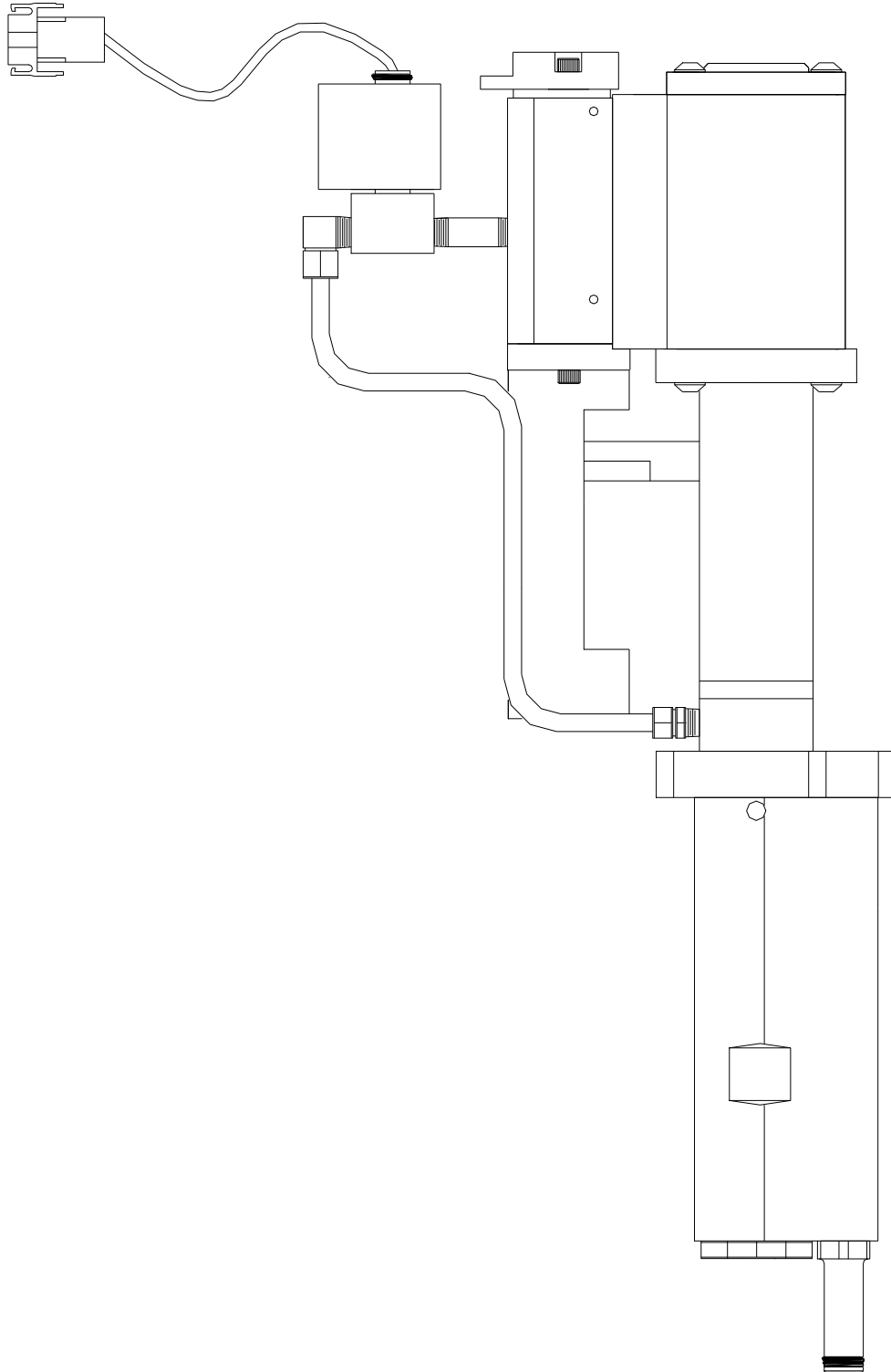

FIGURE 13

MP SHIFTER ASSEMBLY
PART# B100-816

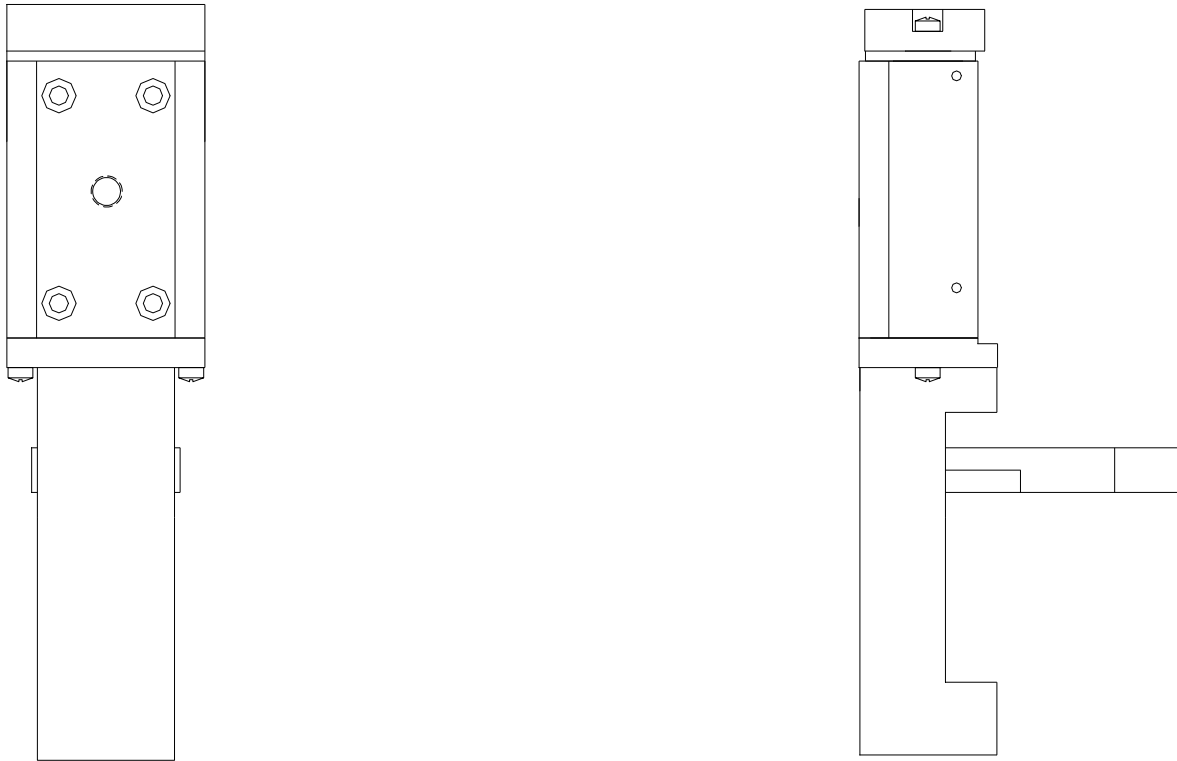

FIGURE 14

TANK THERMOSTAT ASSEMBLY
PART# A100-273

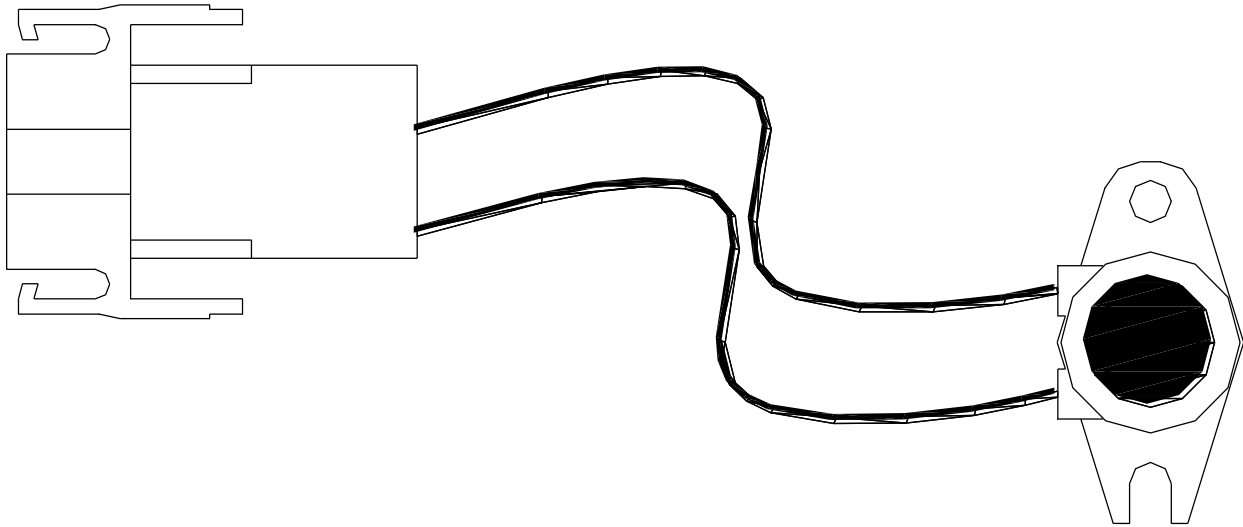

FIGURE 15

TANK RTD ASSEMBLY
PART# A100-274

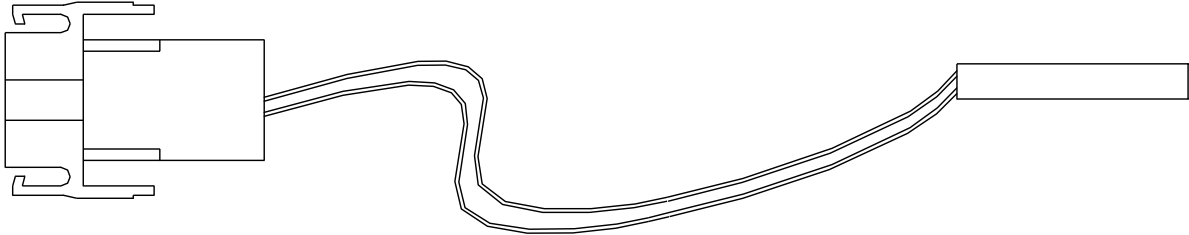

FIGURE 16

TANK RTD & THERMOSTAT LOCATION

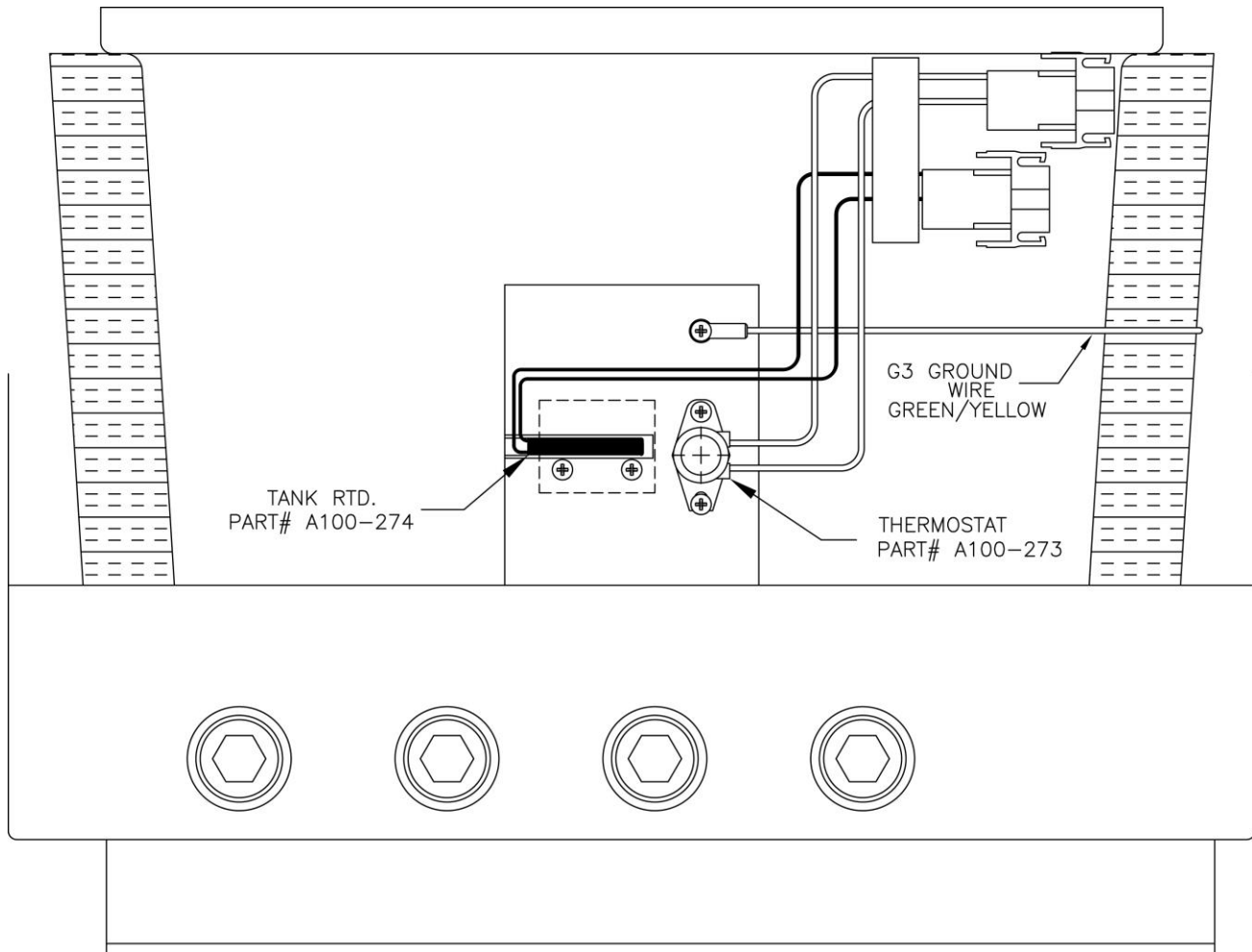

FIGURE 17

HOT MELT ADHESIVE CLEANER

- **NON TOXIC**
- **BIODEGRADABLE**
- **F.D.A. APPROVED**
- **NON-HAZARDOUS BY E.P.A. REGULATIONS**

SUGGESTED USE

- Routine Maintenance
- Product Changes
- Prevention of nozzle clogging, hose constriction, application wheel binding, poor pump stroking.
- Purging char, degraded adhesive, etc.

A PLANNED ROUTINE OF "CLEAN-UPS" WITH **PURGE PLUS** WILL EFFECTIVELY REMOVE DEGREDDATION AND SLUDGE IN "HARD TO REACH", "HARD TO SEE" AREAS AND REDUCE MACHINE REPLACEMENT PARTS COSTS

AVAILABLE IN A 5 GALLON CONTAINER - P/N 62753

**** NOTE: HEAT PURGE PLUS TO 350°F - 375°F FOR OPTIMUM PERFORMANCE ****

DIRECTIONS FOR USE

1. Drain all hot melt from systems.
2. Fill reservoir with **PURGE PLUS**.
3. Heat PURGE PLUS to 350°F - 375°F for approximately 45 minutes.
4. Disconnect hoses at gun heads, put hose end in metal container, start pump, run PURGE PLUS through hose until clean.
5. Stop pump, reconnect hoses to gun heads.
6. Refill reservoir with PURGE PLUS, start pump.
7. Circulate PURGE PLUS through entire system for 5-8 minutes.
8. Drain PURGE PLUS from system.
9. Add new hot melt, recirculate through system.
10. Drain one cup from each hose.

**** NOTE: IF SYSTEM IS ESPECIALLY DIRTY OR CHARRED, REPEAT STEPS 2-9 ****

Packaging Line Hot Melt Equipment Maintenance Recommendations



Based on how many hours you run your hot melt system

	Hours Run	Service Type	Recommendations	Replacement Part #	Service check
Melter	500	Replace Tank Filter	Keep 2 spare filter per tank		<input type="checkbox"/>
	1000	Clean tank with Purge Plus	Clean tank reservoir		<input type="checkbox"/>
Pump	2500	Clean and Flush Pump	Send in pump for clean and flush of all char		<input type="checkbox"/>
	5000	Replace Pump	Send old pump in for rebuild		<input type="checkbox"/>
Hose	Stops Heating	Replace Hose	Keep 1 spare hose for each size used		<input type="checkbox"/>
In-line Filters	150	Replace Filter	Keep 5 spare filters for each filter body		<input type="checkbox"/>
Gun Head	Stops Functioning	Replace Gun Head	Keep 1 spare gun head for each type used		<input type="checkbox"/>
Module	1000	Change Module	Match spare quantity to the number of modules on each gun head		<input type="checkbox"/>
Nozzles	120	Replace Nozzle	Keep 6 spare nozzles per line		<input type="checkbox"/>



**Optimize
Performance**



**Ensure
Quality**



**Improve
Performance
Life**

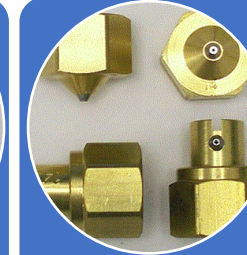

**Easy
Installation**



**Reduce
Charring**

The Universal Systems Advantage



Top Rated USA Manufacturer

- ❖ Universal Systems SE is one of the top rated adhesive equipment manufacturers in the United States. Our main facility is located in Delray Beach, FL.
- ❖ Over 35 years in business.
- ❖ Our clients have reported thousands of dollars per year in cost savings.
- ❖ Universal Systems encourages referral business! All referrals will receive a 10% discount on their next order.
- ❖ 10-year tank warranty – the longest in the industry!
- ❖ Highly trained Customer Service representatives to help you with any technical issues, quotes or orders.

For more information, speak with your Universal Systems representative or contact us directly:

Sales:
Meredith Jenners
meredith@ussefl.com
(800) 848-5018

Find us on:



UNIVERSAL SYSTEMS SE
1085 SW 15TH AVE. SUITE 2
DELRAY BEACH, FL 33444



(561) 272-5442
SALES@USSEFL.COM
WWW.USSEFL.COM